

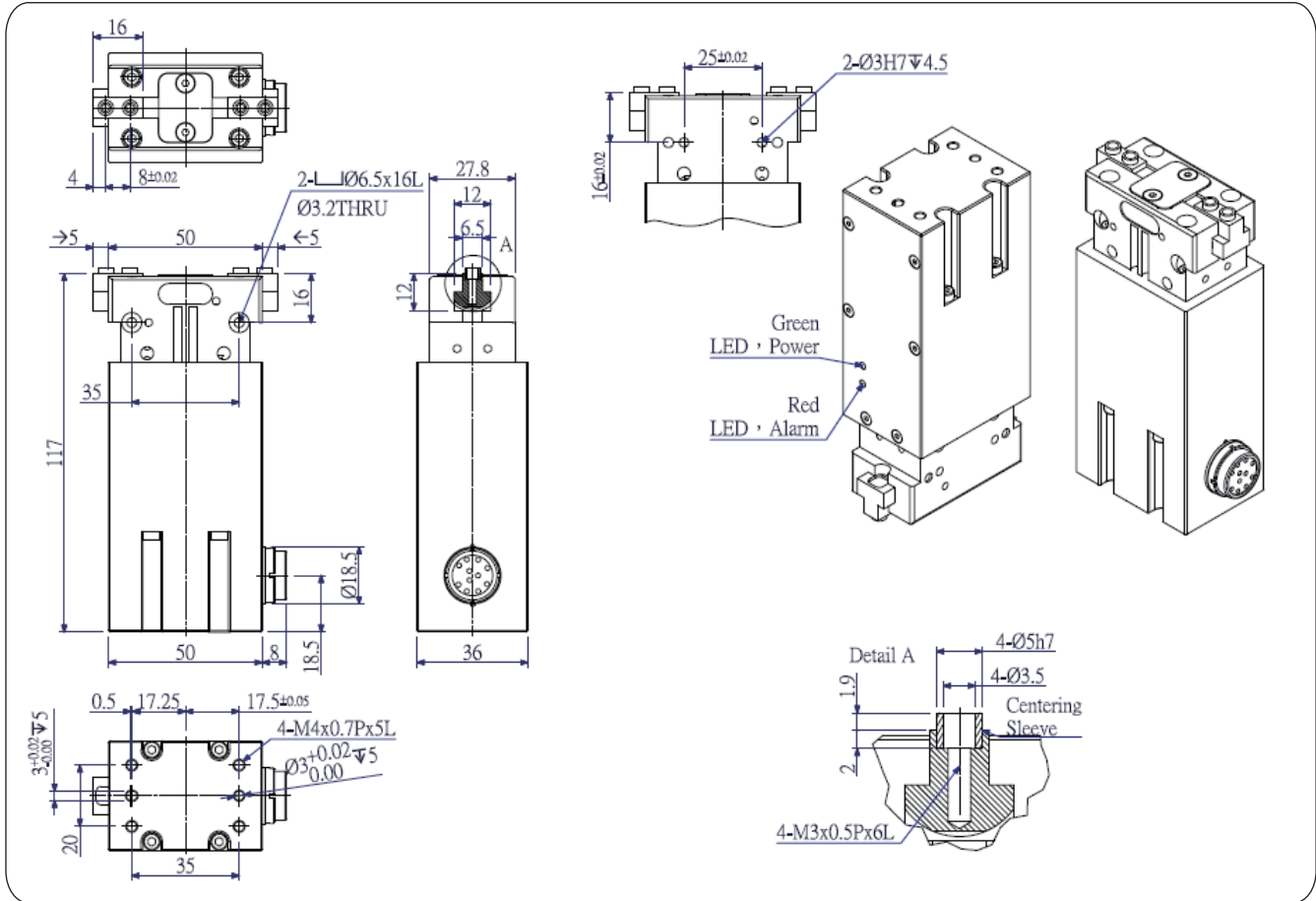

EGN-50

技術資料 Technical data

型號 Model		EGN-50
單爪行程 Stroke per jaw	mm	5
夾持力量-小 Gripping Force- Light	N	10
夾持力量-大 Gripping Force- Heavy	N	30
夾持速度 Clamping speed	mm/s	15
快速移動速度 Fast Move Speed	mm/s	30
最小/最大溫度 Min. /max. temperature	°C	5 - 60
操作電壓 Operating voltage	V	24
操作電流 Operating current	A	1
IP等級 IP rating	IP	40
單指最大重量 The maximum weight of a single finger	g	200
承載扭矩 Bearing torque Mx	N-m	7
承載扭矩 Bearing torque My	N-m	5
承載扭矩 Bearing torque Mz	N-m	5
承載力量 Bearing strength	N	150

外觀尺寸圖 Dimensions



● 連線介面 Connection interface

接頭腳位 Pin connector	I/O	線色 Color Line
10	-	-
9	-	-
8	OU3	橙-Orange
7	IN3	藍-blue
6	IN2	棕-Palm
5	IN1	黃-yellow
4	OU2	綠-green
3	OU1	白-White
2	0V	黑-black
1	24V	紅-red

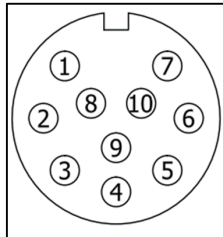

● LED指示燈 LED lights

名稱	顏色	功能
Power	綠	電源指示燈
Alarm	紅	警示燈

警示排除Warning Exclusion:

1. 確認是否有外部異物阻擋夾爪運行
 2. 若無外部異物，請關閉電源並重新啟動
 3. 若完成2且無法排除，請與供應商聯繫
1. Verify that there is foreign matter blocking jaws run
 2. If there is no foreign matter, turn off the power and restart
 3. 2 and 3. When completed can not be excluded, please contact your supplier

● 輸入 IN 簡易I/O控制：3IN/3OUT

IN1	IN2	Function	功能	IN3	Direction	運動方向
0	0	None	無	0	N/A	無
0	0	Reset	初始化	1	Open	開
0	1	Grip (Light force)	夾持(小力量)	0	Close	關
0	1	Grip (Light force)	夾持(小力量)	1	Open	開
1	0	Grip (Heavy force)	夾持(大力量)	0	Close	關
1	0	Grip (Heavy force)	夾持(大力量)	1	Open	開
1	1	Fast Move	快速移動	0	Close	關
1	1	Fast Move	快速移動	1	Open	開

電源指示燈未亮起ower No light:

1. 確認是否成功接通24V與0V電源
 2. 若完成1且無法排除，請與供應商聯繫
1. Verify that successfully switched 24V supply and 0V
 2. If the completion of 1 and can not be excluded, please contact your supplier

● 操作說明Instructions:

1. IN1, IN2先設定功能後，再輸入IN3進行開關動作。
2. 斷電後執行工作前，請先執行Reset。Reset時夾爪行程內請避開異物。

1. IN1, after first setting function IN2, IN3 and then enter the switching operation.
2. After the power before performing work, perform Reset. Reset when the jaws Avoid foreign objects inside the itinerary.

● 輸出 OUT

OUT1	OUT2	OUT3	Feedback	回授訊號	說明
0	0	1	Ready	待命	夾爪待命中，可進行下一動作
1	0	0	Busy	忙碌	夾爪忙碌中，暫不接受指令
0	1	0	Hold	夾持	已夾持到物體，可進行下一動作
0	0	0	Alarm	警示	運作異常，請進行警示排除

EGN-66

技術資料 Technical data

型號 Model		EGN-66
單爪行程 Stroke per jaw	mm	6
夾持力量-小 Gripping Force- Light	N	30
夾持力量-大 Gripping Force- Heavy	N	50
夾持速度 Clamping speed	mm/s	15
快速移動速度 Fast Move Speed	mm/s	30
最小/最大溫度 Min. /max. temperature	°C	5 - 60
操作電壓 Operating voltage	V	24
操作電流 Operating current	A	1
IP等級 IP rating	IP	40
單指最大重量 The maximum weight of a single finger	g	200
承載扭矩 Bearing torque Mx	N-m	7
承載扭矩 Bearing torque My	N-m	5
承載扭矩 Bearing torque Mz	N-m	5
承載力量 Bearing strength	N	200

