

 **SRP-30-D4**

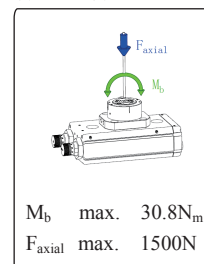

模組出力表Pinion Load



技術資料 Technical data

| 型號 Model | | SRP-30-90-D4 | SRP-30-180-D4 |
|---|-----------------|--|---------------|
| 扭矩Torque | Nm | 10.6 | 10.6 |
| 旋轉角度Rotation angle | N | 90 | 180 |
| 調整角度 Adjust the angle | ° | 3.0 | 3.0 |
| 旋轉時間 Swiveling time with middle attached load | s | 1.4 | 1.4 |
| 雙行程耗氣量 Double-stroke Air consumption | cm ³ | 196 | 196 |
| 內部通氣孔數 Number of internal vent holes | | 4 | 4 |
| 緩衝裝置 Buffering mode | | 可調式油壓緩衝器(1~8段) Adjustable hydraulic shock absorbers (1 to 8) | |
| 最大/最小壓力 Max. pressure | bar | 5/8 | 5/8 |
| 最小/最大溫度 Min. /max. temperature | °C | 5 - 80 | 5 - 80 |
| 夾爪關閉/開啟時間 Gripping Closing/opening Time | s | 0.5 | 0.5 |
| IP等級 IP Class | IP | 65 | 65 |
| 重量 Weight | KG | 3.7 | 3.7 |

訂購代號 How to code

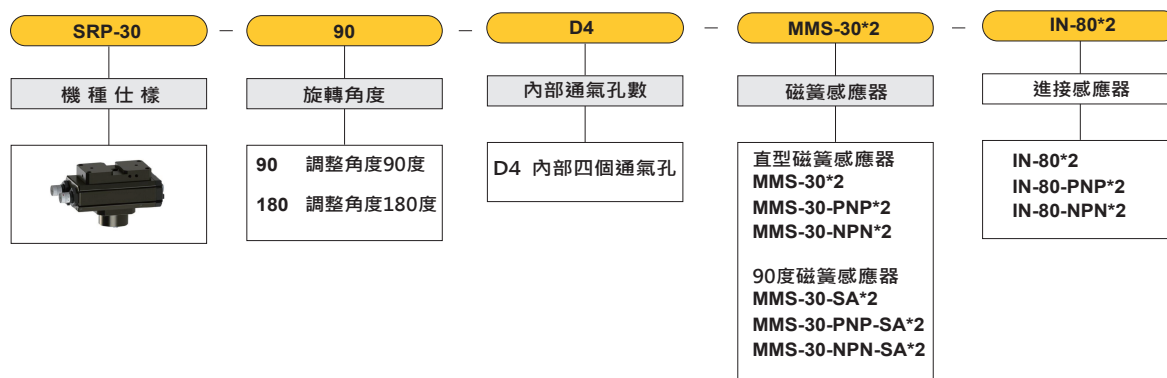

外觀尺寸圖 Dimensions

SRP-30-D4

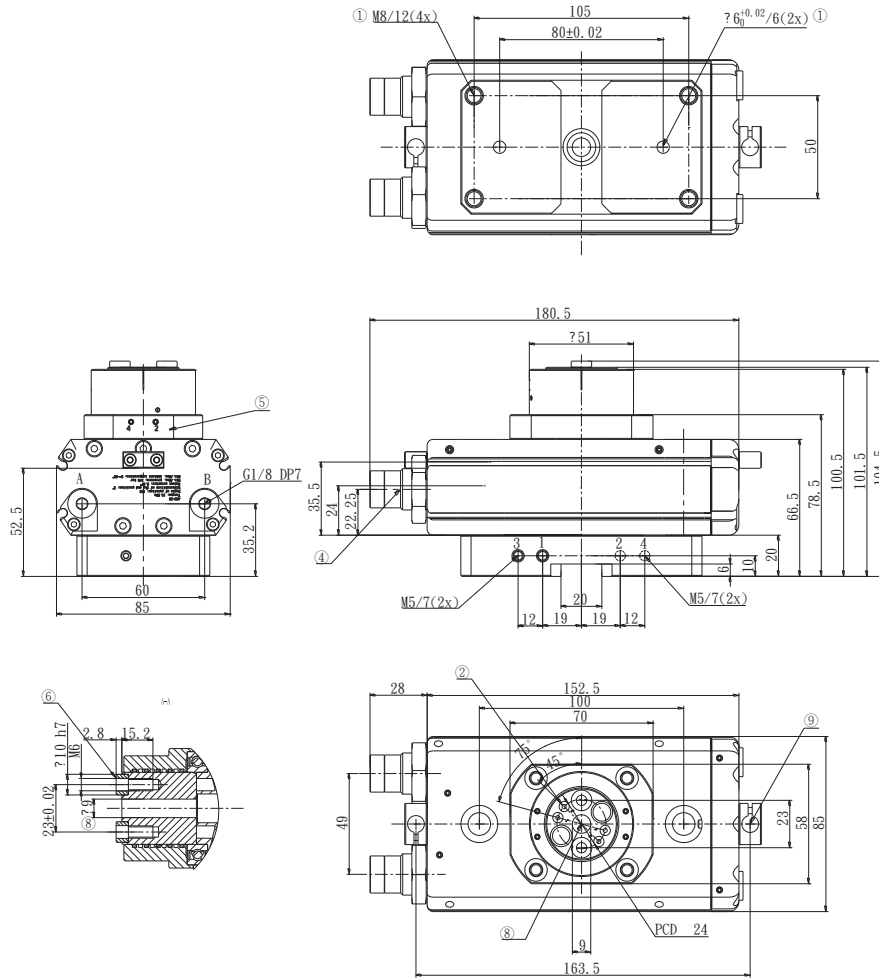

A、a 轉位模組順時針旋轉進氣口； The indexing unit rotates the air inlet clockwise
 B、b 轉位模組逆時針旋轉進氣口； The indexing unit rotates the air intake counterclockwise;

- ① 轉位模組連接板 Indexing module connection plate
- ② 內部氣孔 Fluid feed - through
- ④ 緩衝器 /限位 Setting absorber shock and limiting
- ⑤ 磁性開關安裝槽 Slot for magnetic field sensor
- ⑥ 連接法蘭 Connecting flange
- ⑧ 中心孔 Center Bore

● 旋轉模組連接供氣接口/The rotary module connects the air supply interface

● 直接連接供氣接口· 免管線· 連接板與手爪供氣孔直接相連· 壓縮空氣直接供氣給機械夾爪使用

● Directly connected to the air supply interface, free pipe, connecting plate and the hand plug air supply directly connected to the compressed air directly to the mechanical use of the jaws

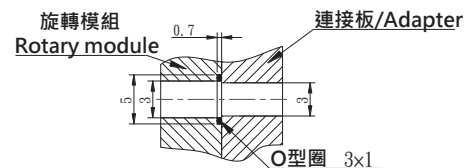

SRP-30-D4

● (無接觸式)近接感應器開關
(Contactless) proximity sensor switch

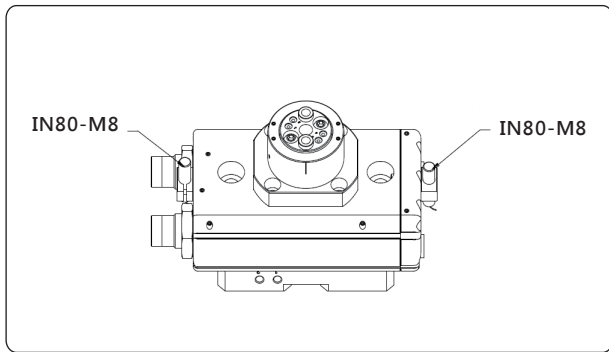

- (無接觸式)側邊終端位置監控:
旋轉缸模組感應器，可直接由側邊安裝。
- 每個旋轉缸模組需要至少2個感應器(無接觸式)。
- (Non-contact) side terminal position monitoring:
Rotary cylinder module sensor, can be installed directly from the side
- Each rotary cylinder module requires at least two sensors (no contact).

| 型號 Model | 建議使用數量 Recom. number of use |
|-------------|--------------------------------|
| IN80-M8 | 2 |
| IN80-M8-NPN | 2 |
| IN80-M8-PNP | 2 |

● 旋轉模組調速閥 Rotating module speed regulating valve

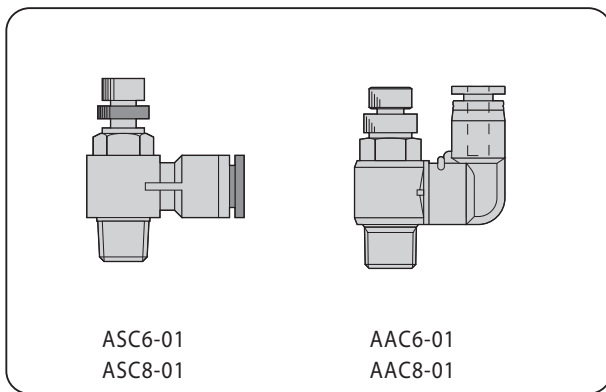

- 旋轉模組專用調速閥:
調整旋轉模組速度專用調速閥門
- 每個旋轉模組需要至少2個調速閥。
- Rotary module special speed control valve:
Adjust the speed of the rotary module for special speed control valve
- Each rotary module requires at least two speed control valves.

| 型號 Model | 型式 Description | 建議使用數量 Recom. number of use |
|-------------|---|--------------------------------|
| ASC6-01 | 90度設計 Ø6管徑 90 degrees design ø6 diameter | 2 |
| AAC6-01 | 直通設計 Ø6管徑 Straight design ø6 diameter | 2 |
| ASC8-01 | 90度設計 Ø8管徑 90 degrees design ø6 diameter | 2 |
| AAC8-01 | 直通設計 Ø8管徑 Straight design ø6 diameter | 2 |

● (接觸式)磁簧式C型槽感應器開關
(Contact type) reed type C-slot sensor switch

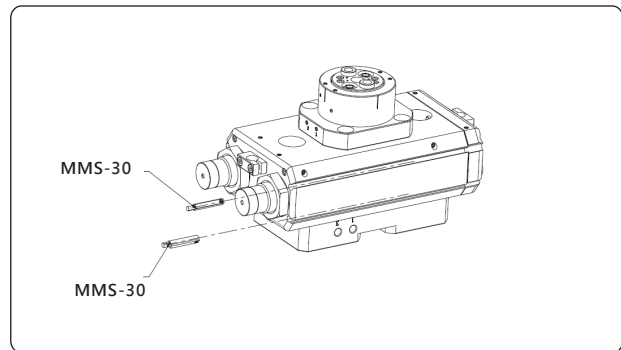

- 接觸式C型槽終端位置監控:
旋轉缸模組感應器，安裝於夾爪C型槽內。
- 每個旋轉缸模組需要至少2個感應器(接觸式)。
- Contact C-slot terminal position monitoring:
Rotary cylinder module sensor, installed in the jaw C-slot.
- Each rotary cylinder module requires at least two sensors (contact type).

| 型號 Model | 型式 Description | 建議使用數量 Recom. number of use |
|---------------|--|--------------------------------|
| MMS-30 | 直行設計(兩線無接點) Straight design (two-line non-contact) | 2 |
| MMS-30-PNP | 直行設計(三線接點) Straight design (two-line non-contact) | 2 |
| MMS-30-NPN | 直行設計(三線接點) Straight design (two-line non-contact) | 2 |
| MMS-30-SA | 90度設計(兩線無接點) 90 degrees design (two-line non-contact) | 2 |
| MMS-30-PNP-SA | 90度設計(三線接點) 90 degrees design (two-line non-contact) | 2 |
| MMS-30-NPN-SA | 90度設計(三線接點) 90 degrees design (two-line non-contact) | 2 |

 **SRP-40-D4**



模組出力表Pinion Load

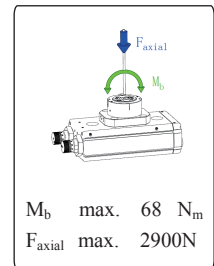

技術資料 Technical data

| 型號 Model | | SRP-40-90-D4 | SRP-40-180-D4 |
|---|-----------------|--|---------------|
| 扭矩Torque | Nm | 22.9 | 22.9 |
| 旋轉角度Rotation angle | N | 90 | 180 |
| 調整角度 Adjust the angle | ° | 3.0 | 3.0 |
| 旋轉時間 Swiveling time with middle attached load | s | 1.4 | 1.4 |
| 雙行程耗氣量 Double-stroke Air consumption | cm ³ | 322 | 322 |
| 內部通氣孔數 Number of internal vent holes | | 4 | 4 |
| 緩衝裝置 Buffering mode | | 可調式油壓緩衝器(1~8段) Adjustable hydraulic shock absorbers (1 to 8) | |
| 最大/最小壓力 Max. pressure | bar | 5/8 | 5/8 |
| 最小/最大溫度 Min. /max. temperature | °C | 5 - 80 | 5 - 80 |
| 夾爪關閉/開啟時間 Gripping Closing/opening Time | s | 0.5 | 0.5 |
| IP等級 IP Class | IP | 65 | 65 |
| 重量 Weight | KG | 5.46 | 5.46 |

訂購代號 How to code

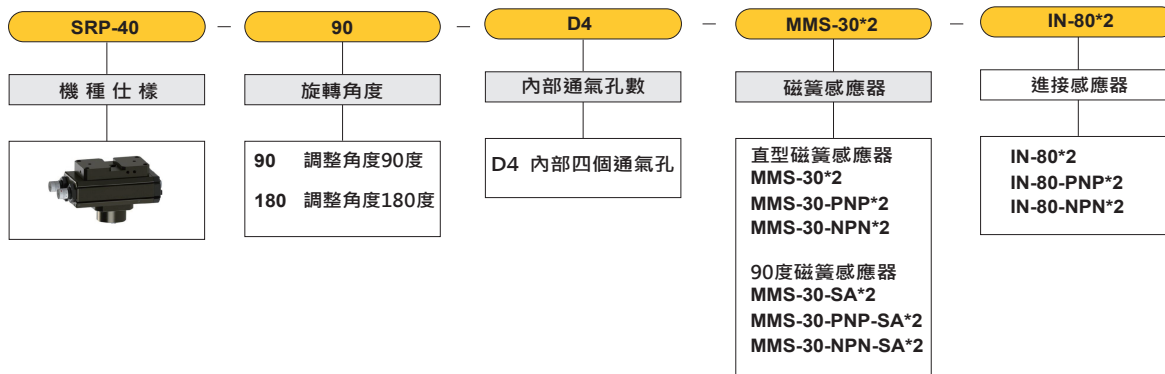

外觀尺寸圖 Dimensions

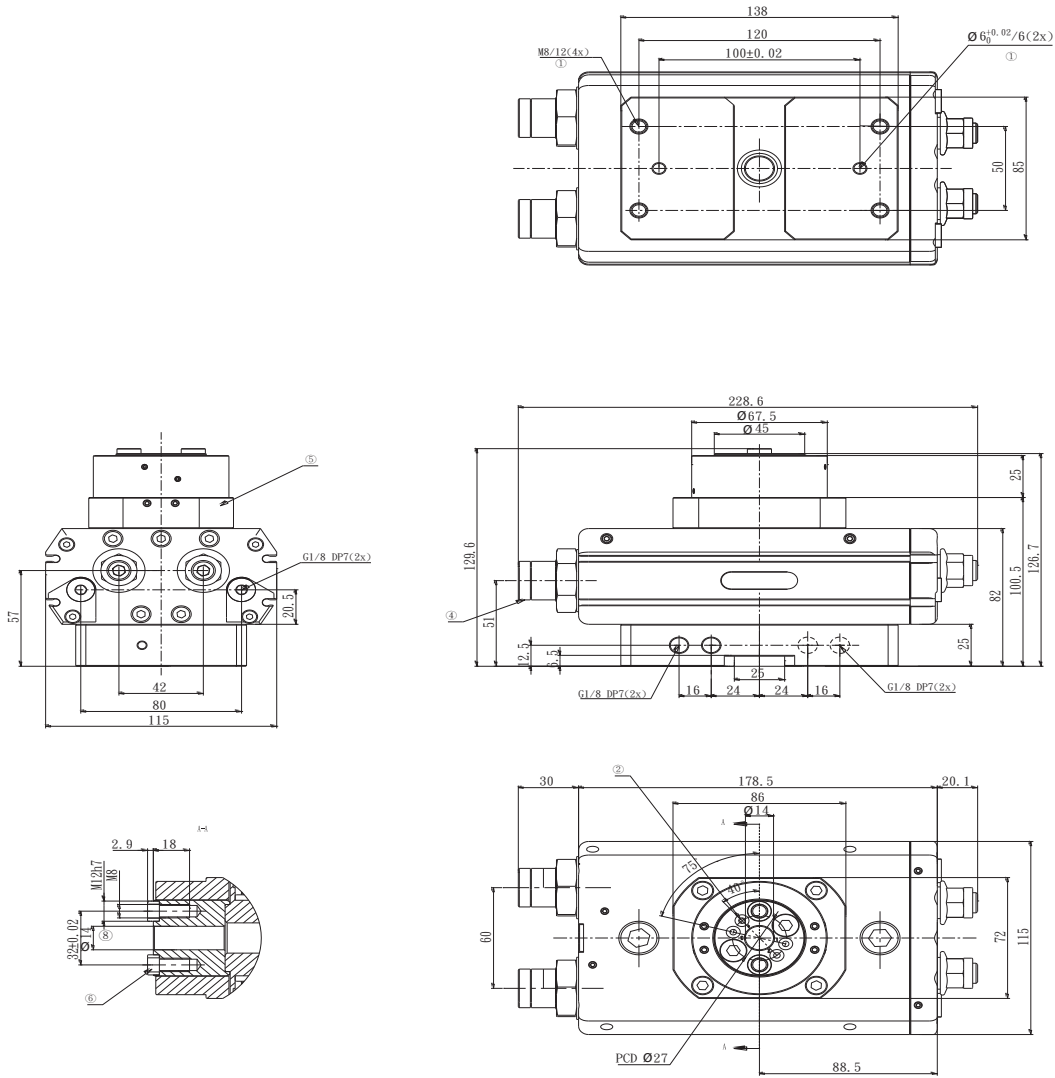

A、a 轉位模組順時針旋轉進氣口； The indexing unit rotates the air inlet clockwise
 B、b 轉位模組逆時針旋轉進氣口； The indexing unit rotates the air intake counterclockwise;

- ① 轉位模組連接板 Indexing module connection plate
- ② 內部氣孔 Fluid feed-through
- ④ 緩衝器 / 限位 Setting absorber shock and limiting
- ⑤ 磁性開關安裝槽 Slot for magnetic field sensor
- ⑥ 連接附件 Attachment connection
- ⑧ 中心孔 Center Bore

SRP-40-D4

● 旋轉模組連接供氣接口/The rotary module connects the air supply interface

- 直接連接供氣接口· 免管線· 連接板與手爪供氣孔直接相連· 壓縮空氣直接供氣給機械夾爪使用
- Directly connected to the air supply interface, free pipe, connecting plate and the hand plug air supply directly connected to the compressed air directly to the mechanical use of the jaws

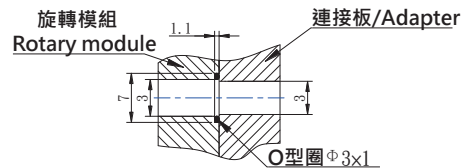

● 外部限位 External Limit Types

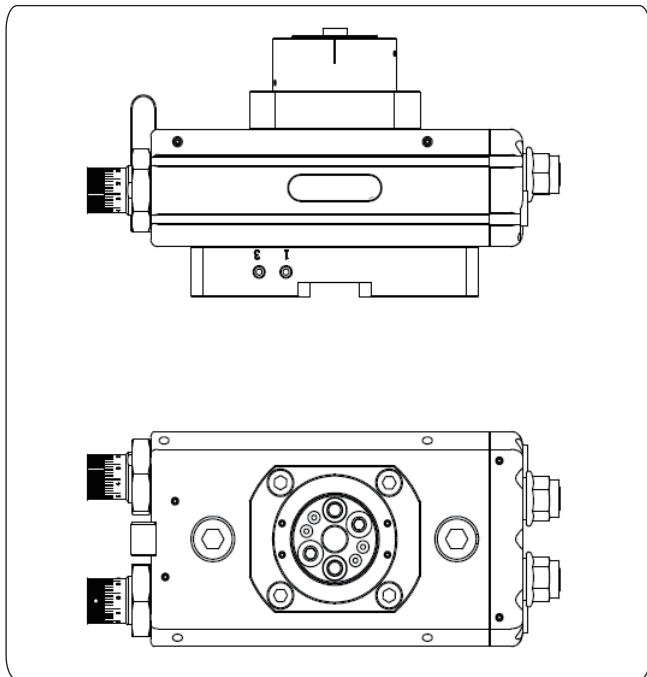

- 上圖為外部限位示意圖
旋轉模組設置有外部限位接口，可以訂購限位附件也可以自行設計限位裝置。
- The schematic for a design of limited block in the figure below.
There is stop block on the swivel unit to ensure limit position. You can order the accessory or design your own limit.

● (接觸式)磁簧式C型槽感應器開關 (Contact type) reed type C-slot sensor switch

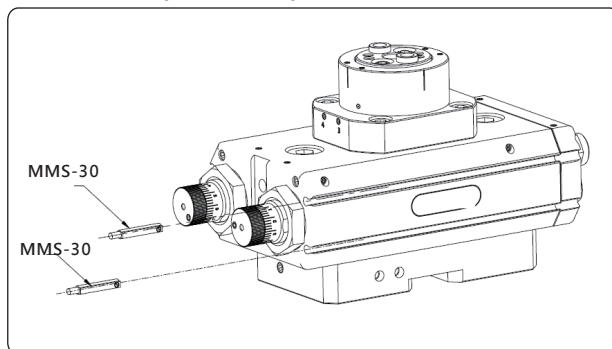

- 接觸式C型槽終端位置監控:
旋轉缸模組感應器，安裝於夾爪C型槽內。
- 每個旋轉缸模組需要至少2個感應器(接觸式)。
- Contact C-slot terminal position monitoring:
Rotary cylinder module sensor, installed in the jaw C-slot.
- Each rotary cylinder module requires at least two sensors (contact type).

| 型號 Model | 型式 Description | 建議使用數量 Recom. number of use |
|---------------|--|--------------------------------|
| MMS-30 | 直行設計(兩線無接點) Straight design (two-line non-contact) | 2 |
| MMS-30-PNP | 直行設計(三線接點) Straight design (two-line non-contact) | 2 |
| MMS-30-NPN | 直行設計(三線接點) Straight design (two-line non-contact) | 2 |
| MMS-30-SA | 90度設計(兩線無接點) 90 degrees design (two-line non-contact) | 2 |
| MMS-30-PNP-SA | 90度設計(三線接點) 90 degrees design (two-line non-contact) | 2 |
| MMS-30-NPN-SA | 90度設計(三線接點) 90 degrees design (two-line non-contact) | 2 |

● 夾爪調速閥 Speed control valve

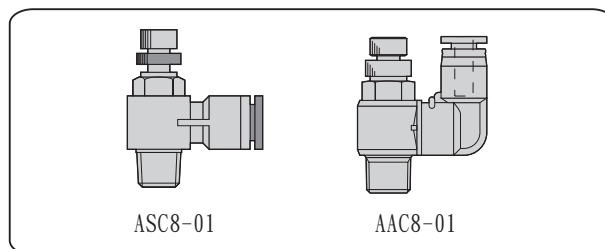

- 機械夾爪專用調速閥:
調整夾爪開張速度專用調速閥門
- 每個旋轉模組需要至少4個調速閥。
- Mechanical jaw special speed control valve:
Adjust the jaw opening speed special speed control valve
- Each rotary module requires at least four speed control valves.

| 型號 Model | 型式 Description | 建議使用數量 Recom. number of use |
|-------------|---|--------------------------------|
| ASC8-01 | 90度設計 Ø8管徑 90 degrees design ø8 diameter | 2 |
| AAC8-01 | 直通設計 Ø8管徑 Straight design ø8 diameter | 2 |



模組出力表Pinion Load

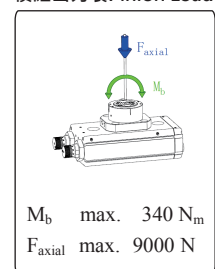

技術資料 Technical data

| 型號 Model | | SRP-50-90-D4 | SRP-50-180-D4 |
|---|-----------------|--|---------------|
| 扭矩Torque | Nm | 49.5 | 49.5 |
| 旋轉角度Rotation angle | N | 90 | 180 |
| 調整角度 Adjust the angle | ° | 3.0 | 3.0 |
| 旋轉時間 Swiveling time with middle attached load | s | 2.2 | 2.2 |
| 雙行程耗氣量 Double-stroke Air consumption | cm ³ | 560 | 560 |
| 內部通氣孔數 Number of internal vent holes | | 4 | 4 |
| 緩衝裝置 Buffering mode | | 可調式油壓緩衝器(1~8段) Adjustable hydraulic shock absorbers (1 to 8) | |
| 最大/最小壓力 Max. pressure | bar | 5/8 | 5/8 |
| 最小/最大溫度 Min. /max. temperature | °C | 5 - 80 | 5 - 80 |
| 夾爪關閉/開啟時間 Gripping Closing/opening Time | s | 0.5 | 0.5 |
| IP等級 IP Class | IP | 40 | 40 |
| 重量 Weight | KG | 10.62 | 10.62 |

訂購代號 How to code

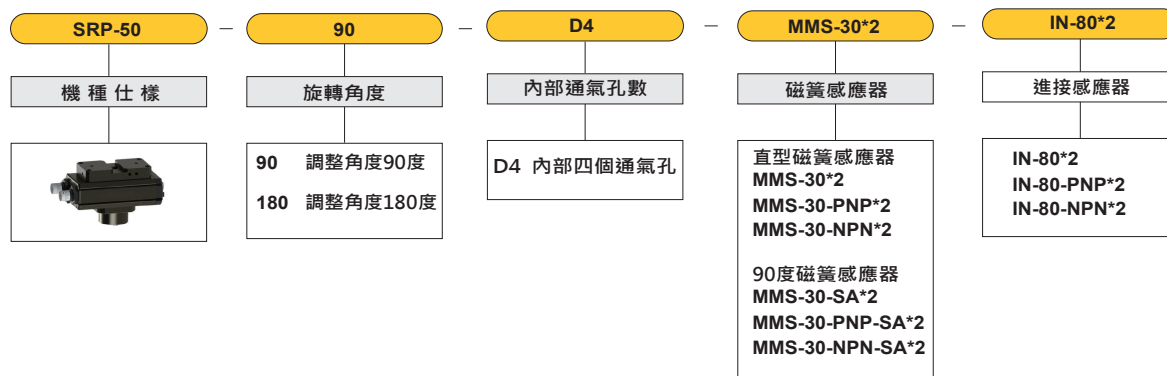

外觀尺寸圖 Dimensions

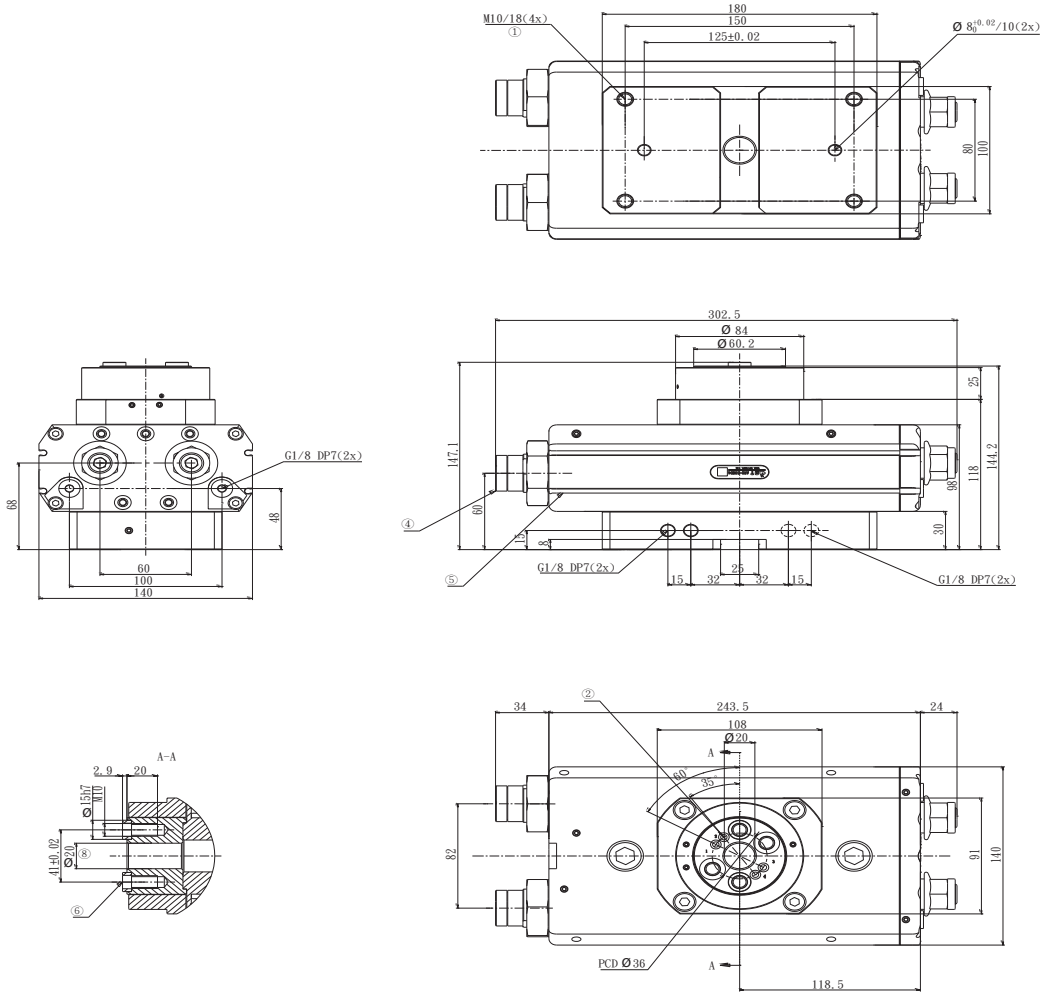

A、a 轉位模組順時針旋轉進氣口； The indexing unit rotates the air inlet clockwise

B、b 轉位模組逆時針旋轉進氣口； The indexing unit rotates the air intake counterclockwise;

- ① 轉位模組連接板 Indexing module connection plate
- ② 內部氣孔 Fluid feed-through
- ④ 緩衝器 / 限位 Setting absorber shock and limiting
- ⑤ 磁性開關安裝槽 Slot for magnetic field sensor
- ⑥ 連接附件 Attachment connection
- ⑧ 中心孔 Center Bore

● 旋轉模組連接供氣接口/The rotary module connects the air supply interface

- 直接連接供氣接口· 免管線· 連接板與手爪供氣孔直接相連· 壓縮空氣直接供氣給機械夾爪使用
- Directly connected to the air supply interface, free pipe, connecting plate and the hand plug air supply directly connected to the compressed air directly to the mechanical use of the jaws

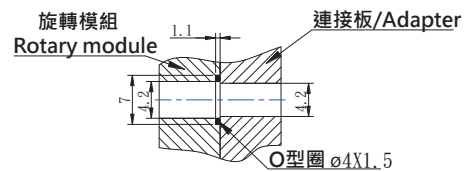

SRP-50-D4

● 外部限位 External Limit Types

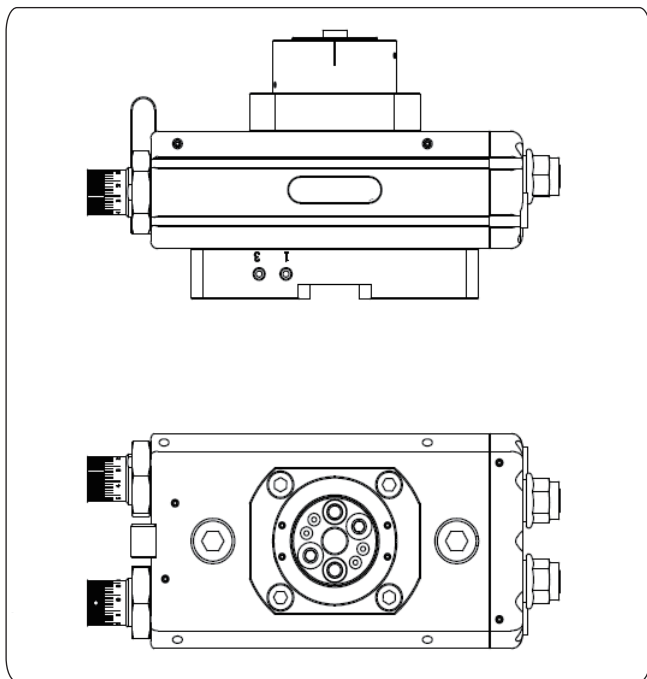

- 上圖為外部限位示意圖
旋轉模組設置有外部限位接口，可以訂購限位附件也可以自行設計限位裝置。
- The schematic for a design of limited block in the figure below.
There is stop block on the swivel unit to ensure limit position. You can order the accessory or design your own limit.

● (接觸式)磁簧式C型槽感應器開關 (Contact type) reed type C-slot sensor switch

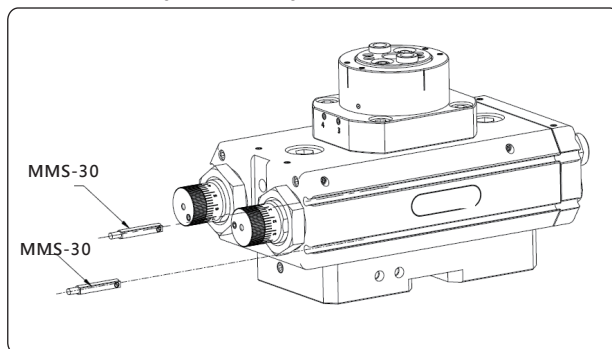

- 接觸式C型槽終端位置監控:
旋轉缸模組感應器，安裝於夾爪C型槽內。
- 每個旋轉缸模組需要至少2個感應器(接觸式)。
- Contact C-slot terminal position monitoring:
Rotary cylinder module sensor, installed in the jaw C-slot.
- Each rotary cylinder module requires at least two sensors (contact type).

| 型號 Model | 型式 Description | 建議使用數量 Recom. number of use |
|---------------|--|--------------------------------|
| MMS-30 | 直行設計(兩線無接點) Straight design (two-line non-contact) | 2 |
| MMS-30-PNP | 直行設計(三線接點) Straight design (two-line non-contact) | 2 |
| MMS-30-NPN | 直行設計(三線接點) Straight design (two-line non-contact) | 2 |
| MMS-30-SA | 90度設計(兩線無接點) 90 degrees design (two-line non-contact) | 2 |
| MMS-30-PNP-SA | 90度設計(三線接點) 90 degrees design (two-line non-contact) | 2 |
| MMS-30-NPN-SA | 90度設計(三線接點) 90 degrees design (two-line non-contact) | 2 |

● 夾爪調速閥 Speed control valve

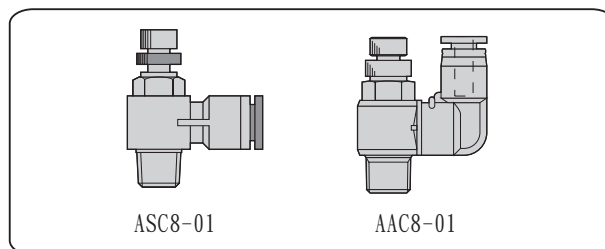

- 機械夾爪專用調速閥:
調整夾爪開張速度專用調速閥門
- 每個旋轉模組需要至少4個調速閥。
- Mechanical jaw special speed control valve:
Adjust the jaw opening speed special speed control valve
- Each rotary module requires at least four speed control valves.

| 型號 Model | 型式 Description | 建議使用數量 Recom. number of use |
|-------------|---|--------------------------------|
| ASC8-01 | 90度設計 Ø8管徑 90 degrees design ø8 diameter | 2 |
| AAC8-01 | 直通設計 Ø8管徑 Straight design ø8 diameter | 2 |