

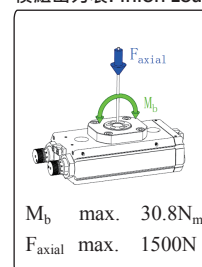

模組出力表Pinion Load



技術資料 Technical data

型號 Model		SRP-30-90	SRP-30-180
扭矩Torque	Nm	10.6	10.6
旋轉角度Rotation angle	N	90	180
調整角度 Adjust the angle	°	3.0	3.0
旋轉時間 Swiveling time with middle attached load	s	1.4	1.4
雙行程耗氣量 Double-stroke Air consumption	cm ³	196	196
緩衝裝置 Buffering mode	可調式油壓緩衝器(1~8段) Adjustable hydraulic shock absorbers (1 to 8)		
最大/最小壓力 Max. pressure	bar	5/8	5/8
最小/最大溫度 Min. /max. temperature	°C	5 - 80	5 - 80
夾爪關閉/開啟時間 Gripping Closing/opening Time	s	0.5	0.5
IP等級 IP Class	IP	65	65
重量 Weight	KG	3.7	3.7

訂購代號 How to code

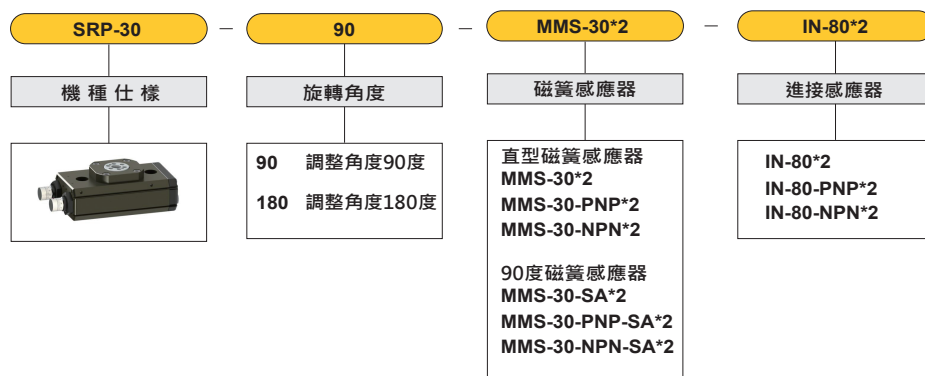

外觀尺寸圖 Dimensions

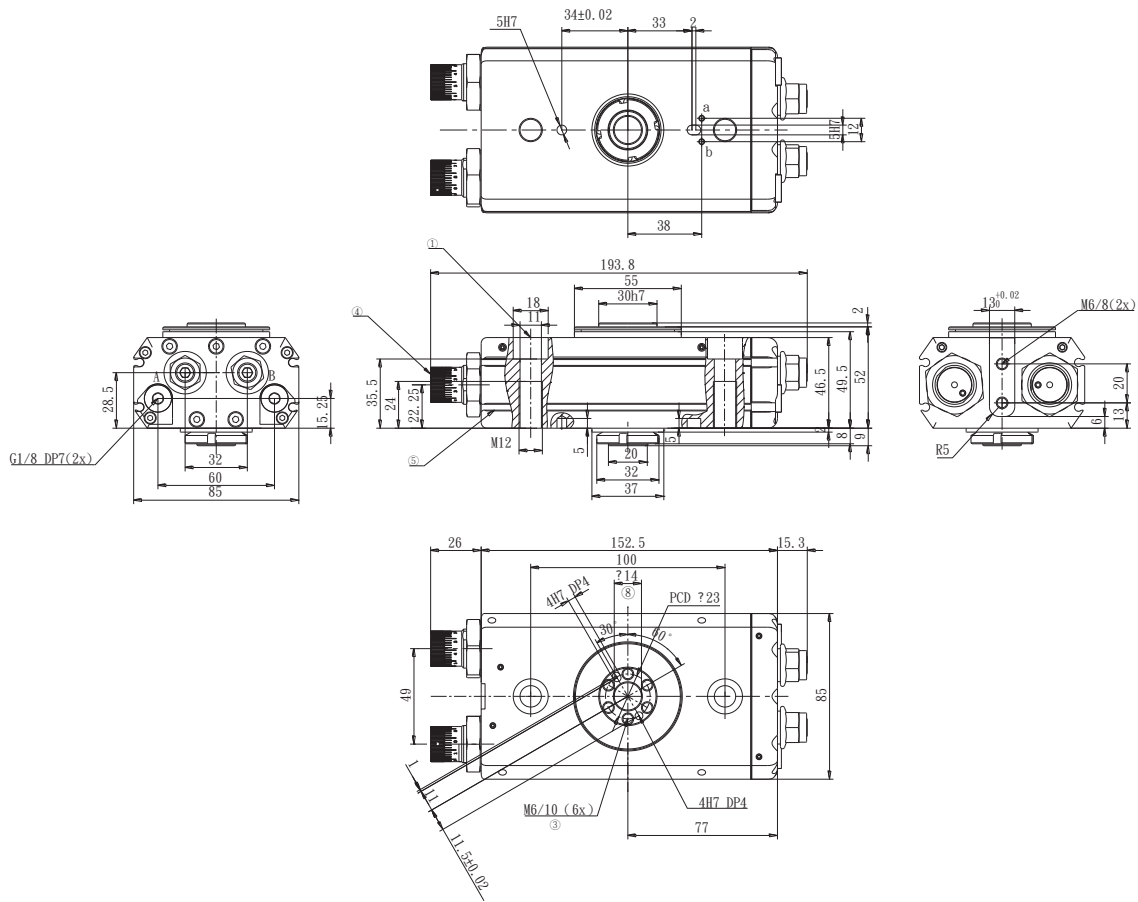

A、a 轉位模組順時針旋轉進氣口； The indexing unit rotates the air inlet clockwise

B、b 轉位模組逆時針旋轉進氣口； The indexing unit rotates the air intake counterclockwise;

- ① 轉位模組連接板 Indexing module connection plate
- ② 內部氣孔 Fluid feed - through
- ④ 緩衝器 / 限位 Setting absorber shock and limiting
- ⑤ 磁性開關安裝槽 Slot for magnetic field sensor
- ⑥ 連接法蘭 Connecting flange
- ⑧ 中心孔 Center Bore

● 旋轉模組連接供氣接口/The rotary module connects the air supply interface

- 直接連接供氣接口·免管線·連接板與手爪供氣孔直接相連·壓縮空氣直接供氣給機械夾爪使用
- Directly connected to the air supply interface, free pipe, connecting plate and the hand plug air supply directly connected to the compressed air directly to the mechanical use of the jaws

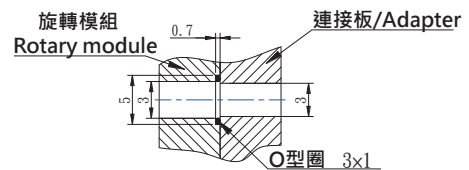

 **SRP-40**



模組出力表Pinion Load

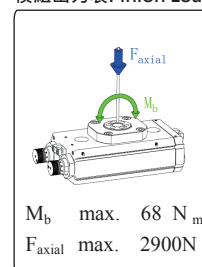

技術資料 Technical data

型號 Model		SRP-40-90	SRP-40-180
扭矩Torque	Nm	22.6	22.6
旋轉角度Rotation angle	N	90	180
調整角度 Adjust the angle	°	3.0	3.0
旋轉時間 Swiveling time with middle attached load	s	1.8	1.8
雙行程耗氣量 Double-stroke Air consumption	cm ³	322	322
緩衝裝置 Buffering mode	可調式油壓緩衝器(1~8段) Adjustable hydraulic shock absorbers (1 to 8)		
最大/最小壓力 Max. pressure	bar	5/8	5/8
最小/最大溫度 Min. /max. temperature	°C	5 - 80	5 - 80
IP等級 IP Class	IP	40	40
重量 Weight	KG	4.17	4.17

訂購代號 How to code

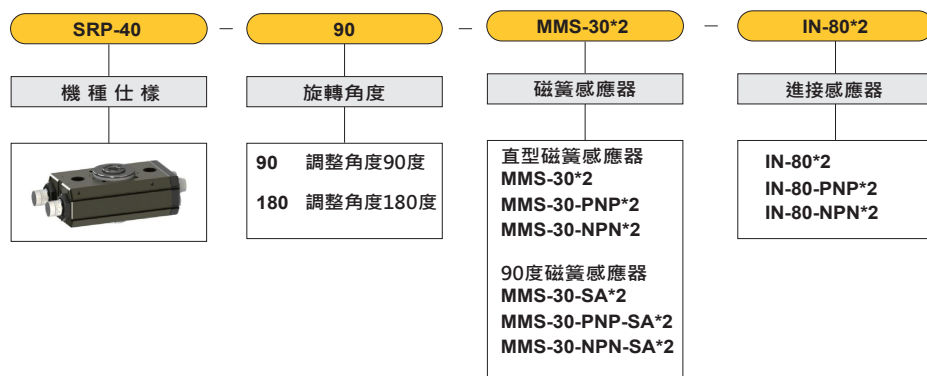

外觀尺寸圖 Dimensions

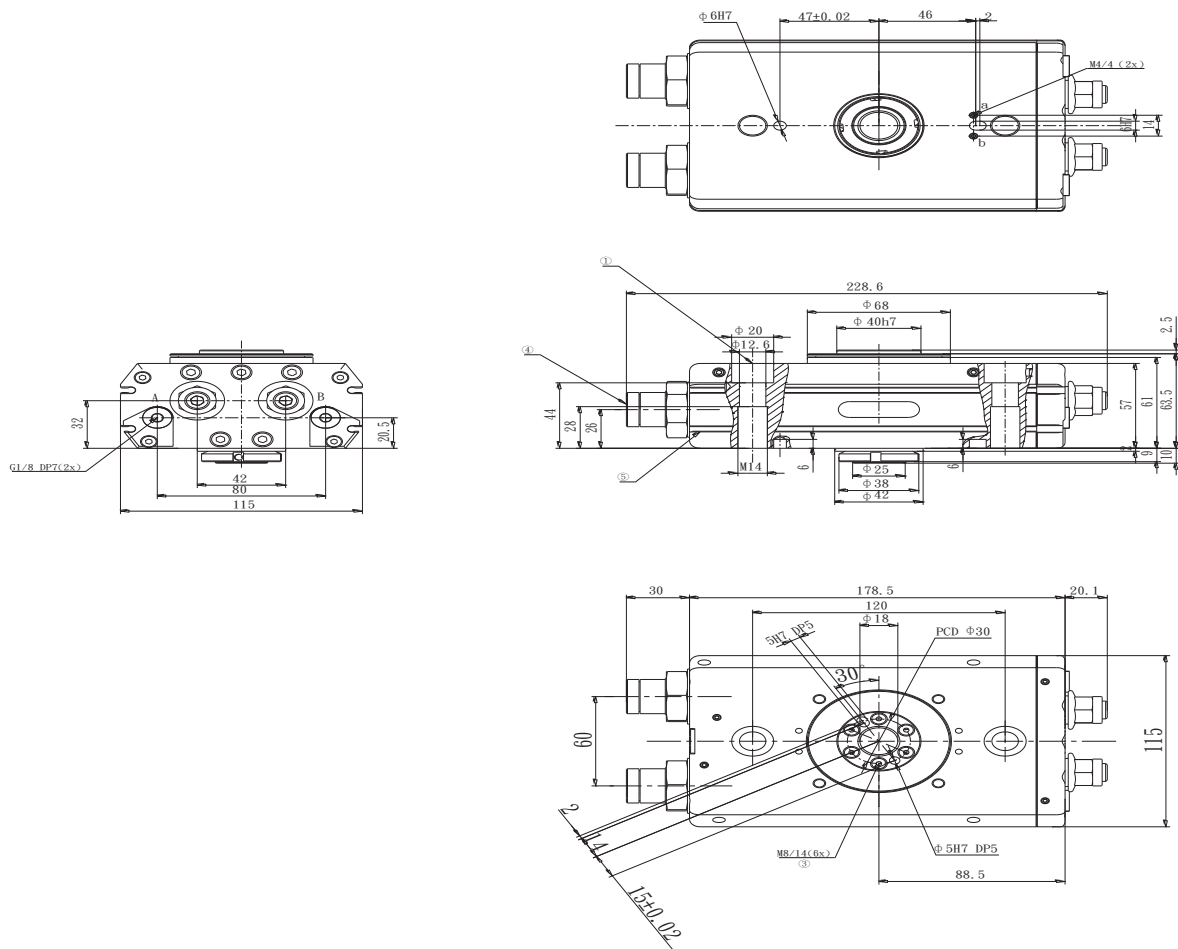

A、a 轉位模組順時針旋轉進氣口； The indexing unit rotates the air inlet clockwise

B、b 轉位模組逆時針旋轉進氣口； The indexing unit rotates the air intake counterclockwise;

- ① 轉位模組連接板 Indexing module connection plate
- ③ 附件連接 Attachment connecting
- ④ 緩衝器 / 限位 Setting absorber shock and limiting
- ⑤ 磁性開關安裝槽 Slot for magnetic field sensor
- ⑧ 中心孔 Center Bore

SRP-40

● 旋轉模組連接供氣接口/The rotary module connects the air supply interface

● 直接連接供氣接口·免管線·連接板與手爪供氣孔直接相連·壓縮空氣直接供氣給機械夾爪使用

● Directly connected to the air supply interface, free pipe, connecting plate and the hand plug air supply directly connected to the compressed air directly to the mechanical use of the jaws

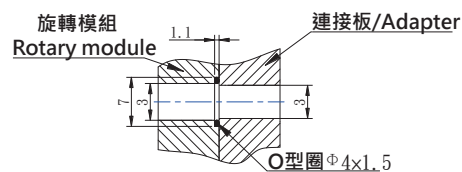

外部限位 External Limit Types

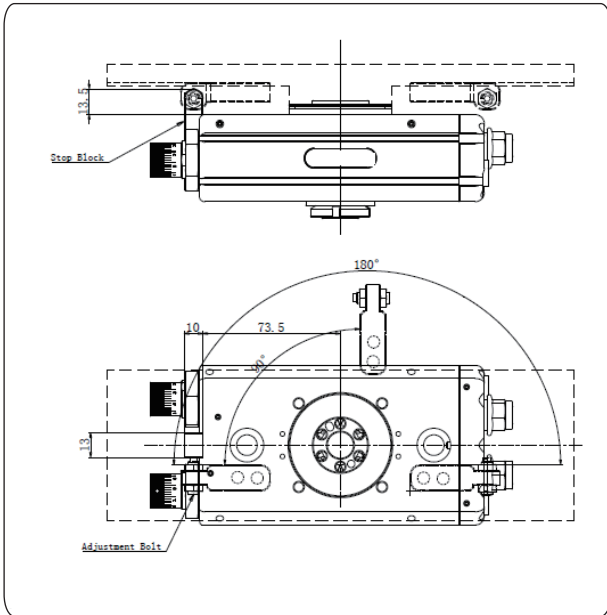

- 上圖為外部限位示意圖
旋轉模組設置有外部限位接口，可以訂購限位附件也可以自行設計限位裝置。
- The schematic for a design of limited block in the figure below.
There is stop block on the swivel unit to ensure limit position. You can order the accessory or design your own limit.

(接觸式)磁簧式C型槽感應器開關 (Contact type) reed type C-slot sensor switch

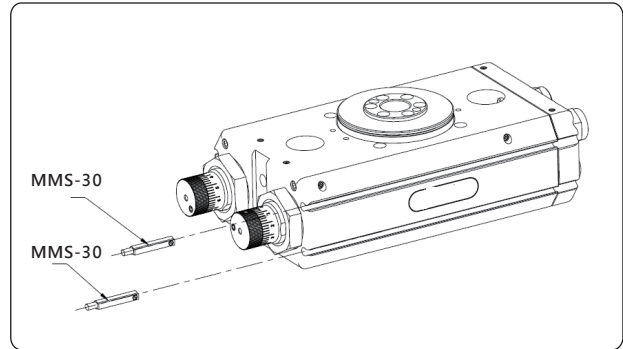

- 接觸式C型槽終端位置監控：
旋轉缸模組感應器，安裝於夾爪C型槽內。
- 每個旋轉缸模組需要至少2個感應器(接觸式)。
- Contact C-slot terminal position monitoring:
Rotary cylinder module sensor, installed in the jaw C-slot.
- Each rotary cylinder module requires at least two sensors (contact type).

型號 Model	型式 Description	建議使用數量 Recom. number of use
MMS-30	直行設計(兩線無接點) Straight design (two-line non-contact)	2
MMS-30-PNP	直行設計(三線接點) Straight design (two-line non-contact)	2
MMS-30-NPN	直行設計(三線接點) Straight design (two-line non-contact)	2
MMS-30-SA	90度設計(兩線無接點) 90 degrees design (two-line non-contact)	2
MMS-30-PNP-SA	90度設計(三線接點) 90 degrees design (two-line non-contact)	2
MMS-30-NPN-SA	90度設計(三線接點) 90 degrees design (two-line non-contact)	2

夾爪調速閥 Speed control valve

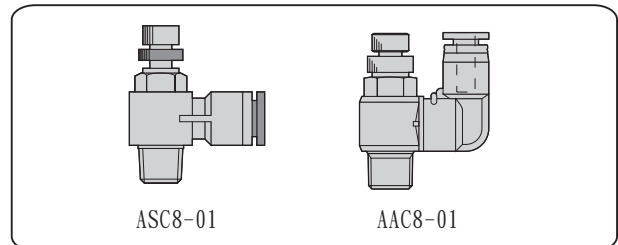

- 機械夾爪專用調速閥：
調整夾爪開張速度專用調速閥門
- 每個旋轉模組需要至少4個調速閥。
- Mechanical jaw special speed control valve:
Adjust the jaw opening speed special speed control valve
- Each rotary module requires at least four speed control valves.

型號 Model	型式 Description	建議使用數量 Recom. number of use
ASC8-01	90度設計 Ø8管徑 90 degrees design ø8 diameter	2
AAC8-01	直通設計 Ø8管徑 Straight design ø8 diameter	2



模組出力表Pinion Load

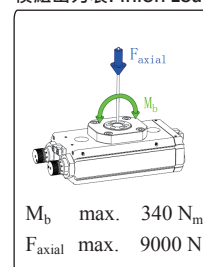

技術資料 Technical data

型號 Model		SRP-50-90	SRP-50-180
扭矩Torque	Nm	49.5	49.5
旋轉角度Rotation angle	N	90	180
調整角度 Adjust the angle	°	3.0	3.0
旋轉時間 Swiveling time with middle attached load	s	2.2	2.2
雙行程耗氣量 Double-stroke Air consumption	cm ³	560	560
緩衝裝置 Buffering mode	可調式油壓緩衝器(1~8段) Adjustable hydraulic shock absorbers (1 to 8)		
最大/最小壓力 Max. pressure	bar	5/8	5/8
最小/最大溫度 Min. /max. temperature	°C	5 - 80	5 - 80
IP等級 IP Class	IP	40	40
重量 Weight	KG	8.35	8.35

訂購代號 How to code

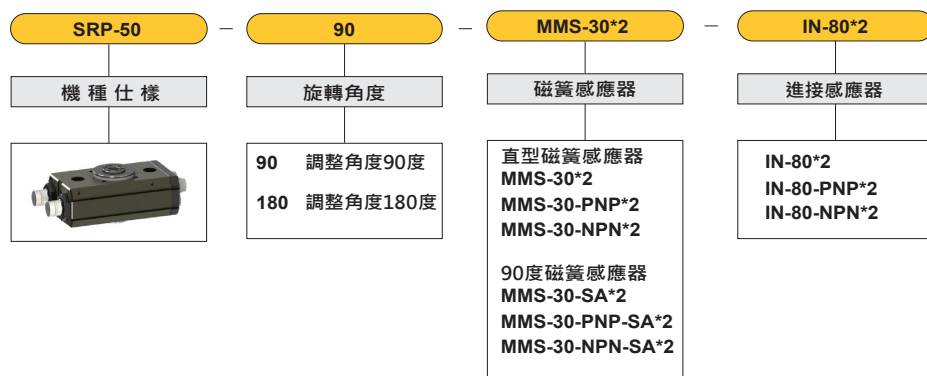

外觀尺寸圖 Dimensions

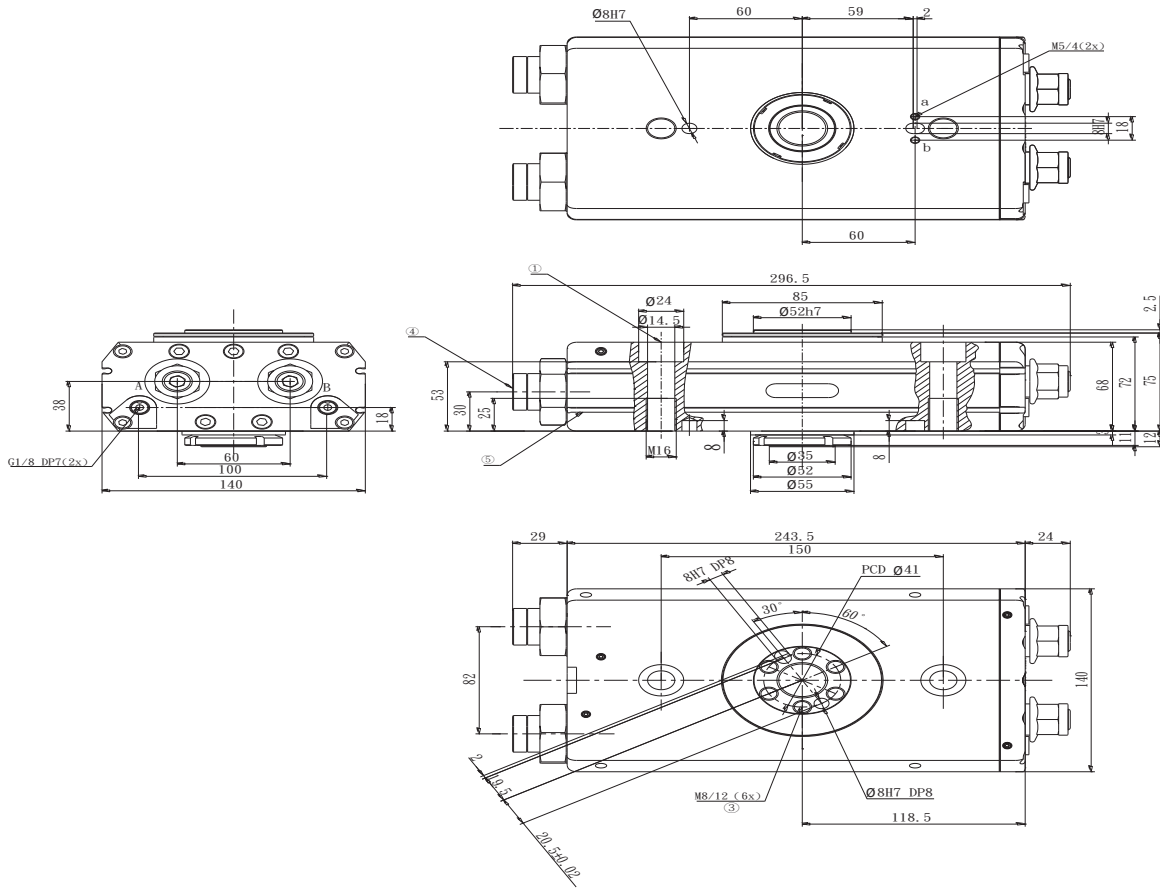

A、a 轉位模組順時針旋轉進氣口； The indexing unit rotates the air inlet clockwise
 B、b 轉位模組逆時針旋轉進氣口； The indexing unit rotates the air intake counterclockwise;

- ① 轉位模組連接板 Indexing module connection plate
- ③ 附件连接 Attachment connecting
- ④ 緩衝器 / 限位 Setting absorber shock and limiting
- ⑤ 磁性開關安裝槽 Slot for magnetic field sensor
- ⑧ 中心孔 Center Bore

SRP-50

● 旋轉模組連接供氣接口/The rotary module connects the air supply interface

- 直接連接供氣接口·免管線·連接板與手爪供氣孔直接相連·壓縮空氣直接供氣給機械夾爪使用
- Directly connected to the air supply interface, free pipe, connecting plate and the hand plug air supply directly connected to the compressed air directly to the mechanical use of the jaws

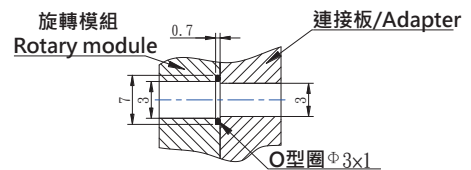

外部限位 External Limit Types

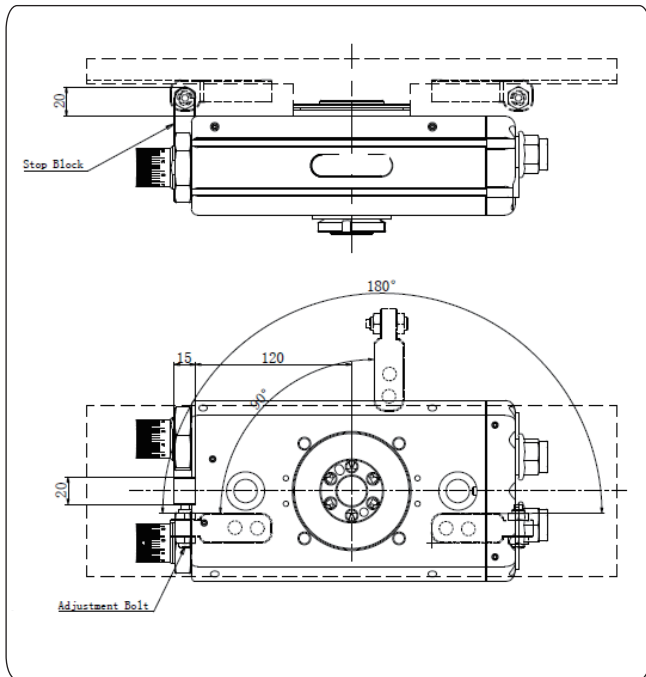

- 上圖為外部限位示意圖
旋轉模組設置有外部限位接口，可以訂購限位附件也可以自行設計限位裝置。
- The schematic for a design of limited block in the figure below.
There is stop block on the swivel unit to ensure limit position. You can order the accessory or design your own limit.

(接觸式)磁簧式C型槽感應器開關 (Contact type) reed type C-slot sensor switch

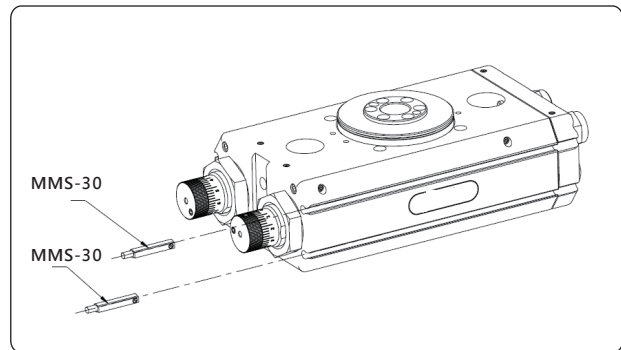

- 接觸式C型槽終端位置監控：
旋轉缸模組感應器，安裝於夾爪C型槽內。
- 每個旋轉缸模組需要至少2個感應器(接觸式)。
- Contact C-slot terminal position monitoring:
Rotary cylinder module sensor, installed in the jaw C-slot.
- Each rotary cylinder module requires at least two sensors (contact type).

型號 Model	型式 Description	建議使用數量 Recom. number of use
MMS-30	直行設計(兩線無接點) Straight design (two-line non-contact)	2
MMS-30-PNP	直行設計(三線接點) Straight design (two-line non-contact)	2
MMS-30-NPN	直行設計(三線接點) Straight design (two-line non-contact)	2
MMS-30-SA	90度設計(兩線無接點) 90 degrees design (two-line non-contact)	2
MMS-30-PNP-SA	90度設計(三線接點) 90 degrees design (two-line non-contact)	2
MMS-30-NPN-SA	90度設計(三線接點) 90 degrees design (two-line non-contact)	2

夾爪調速閥 Speed control valve

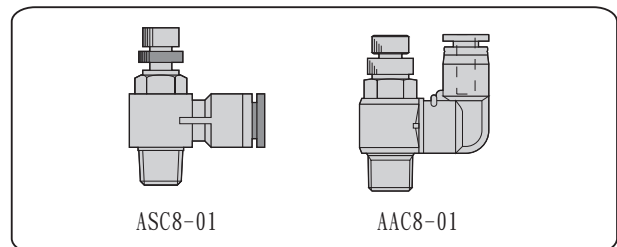

- 機械夾爪專用調速閥：
調整夾爪開張速度專用調速閥門
- 每個旋轉模組需要至少4個調速閥。
- Mechanical jaw special speed control valve:
Adjust the jaw opening speed special speed control valve
- Each rotary module requires at least four speed control valves.

型號 Model	型式 Description	建議使用數量 Recom. number of use
ASC8-01	90度設計 Ø8管徑 90 degrees design ø8 diameter	2
AAC8-01	直通設計 Ø8管徑 Straight design ø8 diameter	2