

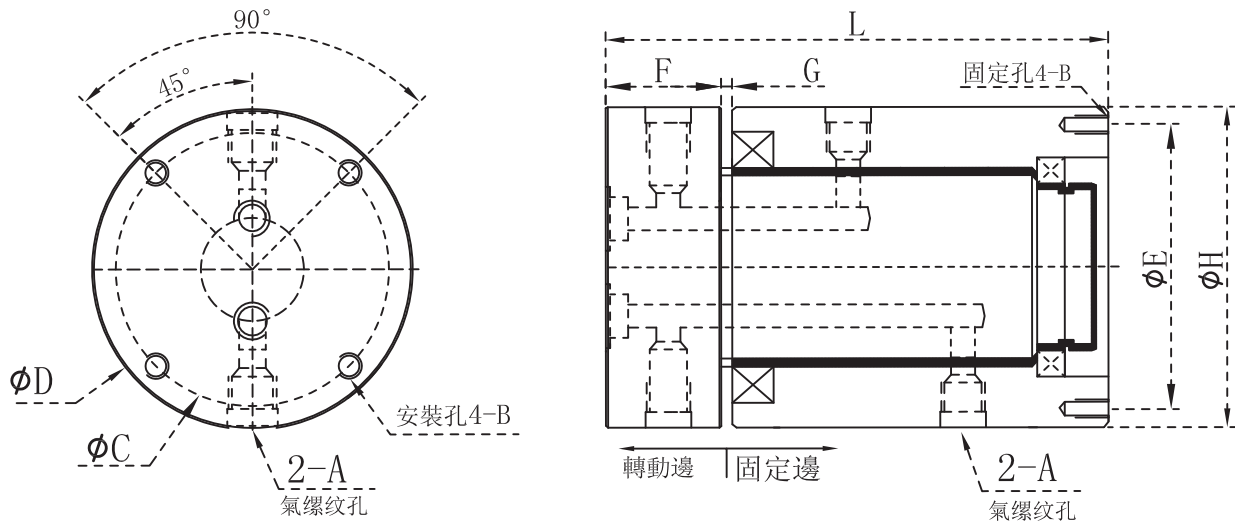

技術資料 Technical data

回路數Number of loops	兩通路型	三通路型	四通路型	六通路型	八通路型	十通路型	十二通路型	十六通路型
型號 Model	SQR2-M5	SQR3-M5	SQR4-M5	SQR6-M5	SQR8-M5	SQR10-M5	SQR12-M5	SQR16-M5
本體孔位Body hole	M5	M5	M5	M5	M5	M5	M5	M5
型號 Model	SQR2-R01	SQR3-R01	SQR4-R01	SQR6-R01	SQR8-R01	SQR10-R01	SQR12-R01	SQR16-R01
本體孔位Body hole	G1/8	G1/8	G1/8	G1/8	G1/8	G1/8	G1/8	G1/8
型號 Model	SQR2-R02	SQR3-R02	SQR4-R02	SQR6-R02	SQR8-R02	SQR10-R02	SQR12-R02	SQR16-R02
本體孔位Body hole	G1/4	G1/4	G1/4	G1/4	G1/4	G1/4	G1/4	G1/4
型號 Model	SQR2-R03	SQR3-R03	SQR4-R03	SQR6-R03	SQR8-R03	-	-	-
本體孔位Body hole	G3/8	G1/8	G1/8	G1/8	G1/8	-	-	-
型號 Model	SQR2-R04	SQR3-R04	SQR4-R04	SQR6-R04	SQR8-R04	-	-	-
本體孔位Body hole	G1/2	G1/2	G1/2	G1/2	G1/2	-	-	-
型號 Model	SQR2-R05	SQR3-R05	SQR4-R05	SQR6-R05	SQR8-R05	-	-	-
本體孔位Body hole	G3/4	G3/4	G3/4	G3/4	G3/4	-	-	-
最高轉速Maximum speed	RPM				500			
最大/最小壓力 Max. pressure	bar				3/20			
最小/最大溫度 Min./max. temperature	°C				5 - 128			
使用流体 Use fluid	真空Vacuum 壓縮空氣Compressed Air							
IP等級 IP Class	IP				65			

SQR2 二迴路 外觀尺寸圖 Dimensions



型號/尺寸	A	B	C	D	E	F	G	H	L
SQR2-R05	M5	M6	30	40	30	15	1	40	60
SQR2-R81	G1/8	M6	35	45	35	18	1	45	65
SQR2-R41	G1/4	M6	45	55	45	22	1	55	81

SQR

SQR3 三迴路 外觀尺寸圖 Dimensions

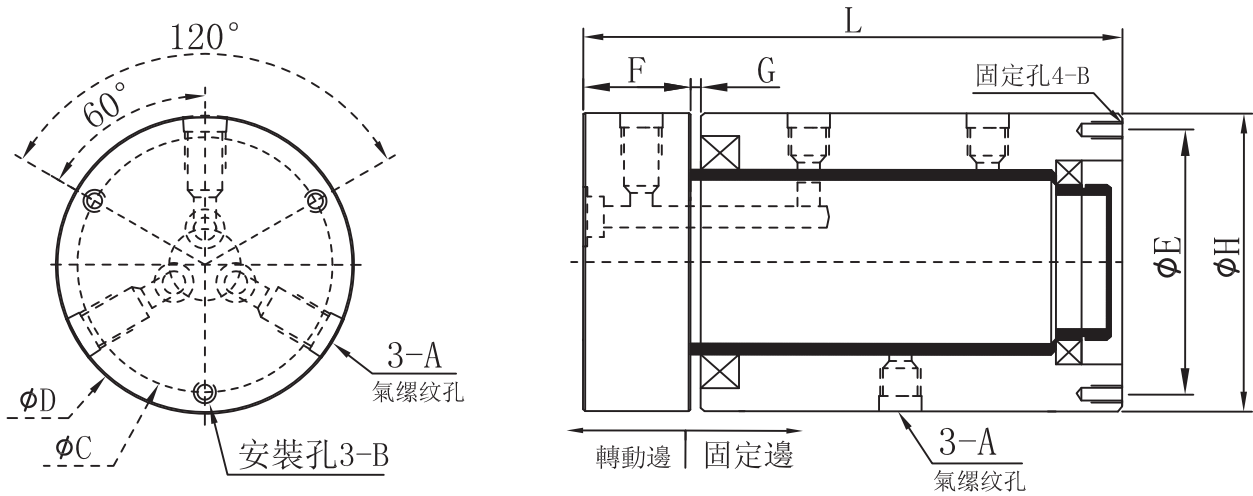

型號/尺寸	A	B	C	D	E	F	G	H	L
SQR3-R05	M5	M6	30	40	30	15	1	40	69
SQR3-R81	G1/8	M6	35	45	35	18	1	45	74
SQR3-R41	G1/4	M6	45	55	45	22	1	55	92

SQR4 四迴路 外觀尺寸圖 Dimensions

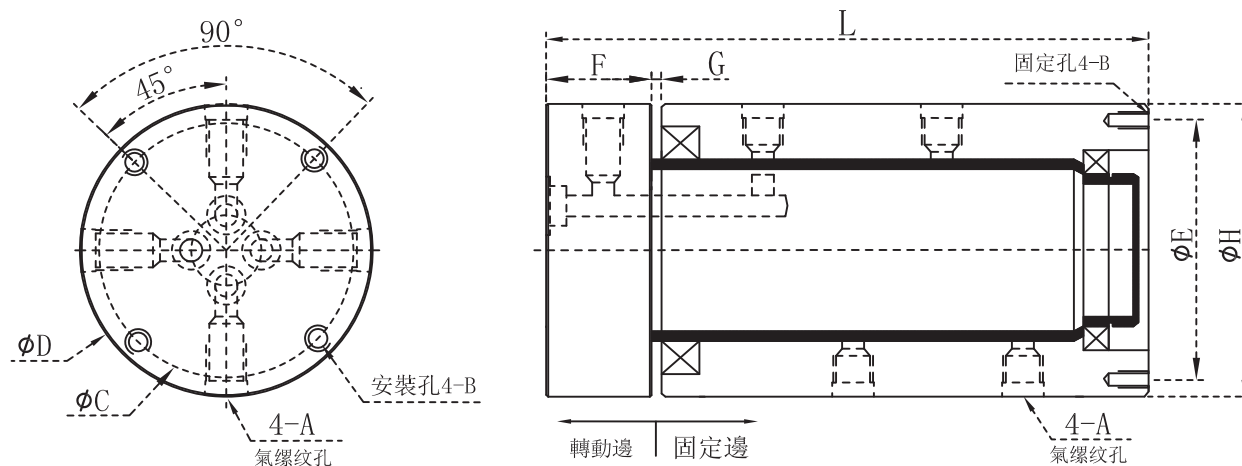

型號/尺寸	A	B	C	D	E	F	G	H	L
SQR4-R05	M5	M6	30	40	30	15	1	40	77
SQR4-R81	G1/8	M6	35	45	35	18	1	50	92
SQR4-R41	G1/4	M6	45	55	45	22	1	55	103

SQR6 六迴路 外觀尺寸圖 Dimensions

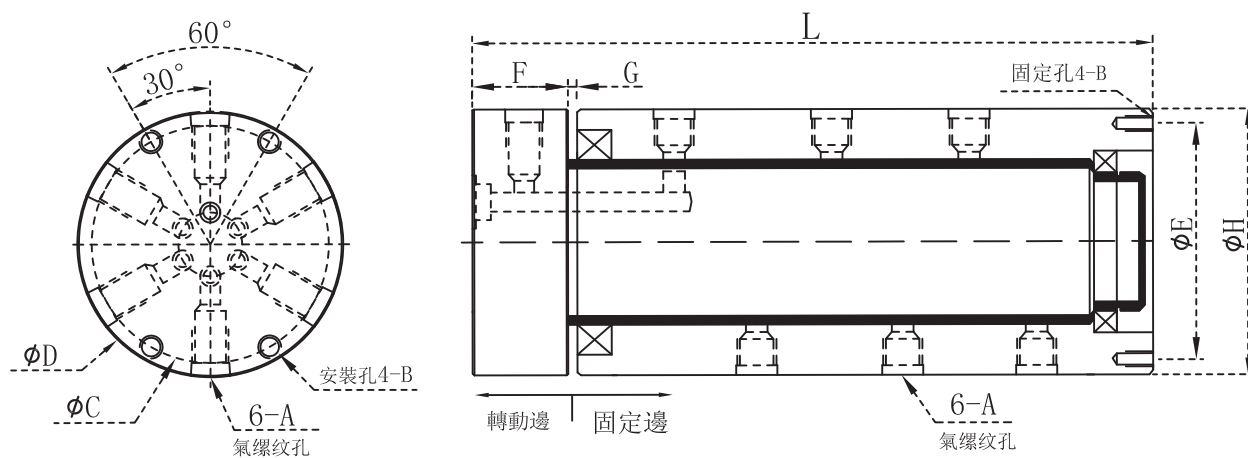

型號/尺寸	A	B	C	D	E	F	G	H	L
SQR6-R05	M5	M6	40	50	40	15	1	50	103
SQR6-R81	G1/8	M6	45	55	45	18	1	55	112
SQR6-R41	G1/4	M6	50	60	50	22	1	60	127

SQR8 八迴路 外觀尺寸圖 Dimensions

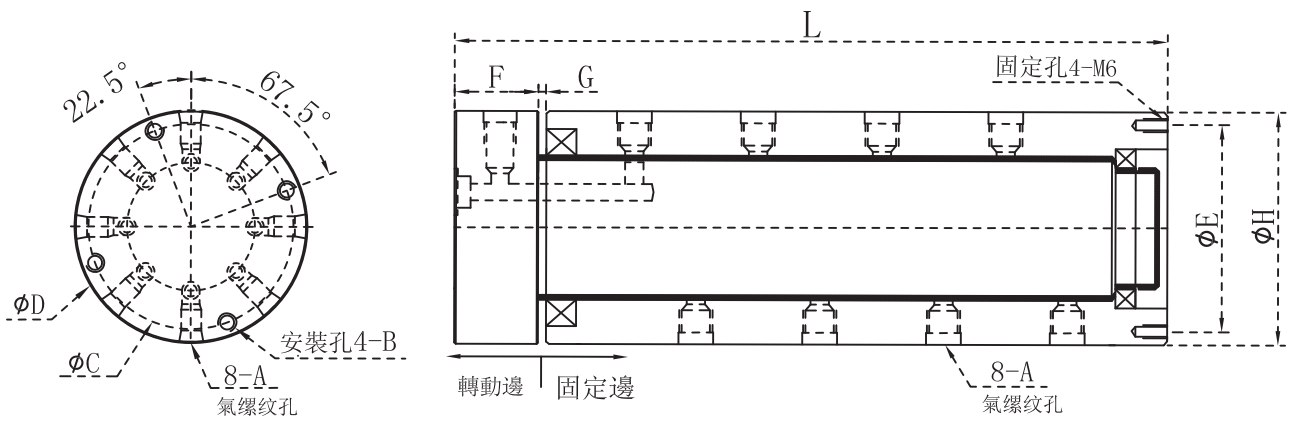

型號/尺寸	A	B	C	D	E	F	G	H	L
SQR8-R05	M5	M6	40	50	40	19	1	50	126
SQR8-R81	G1/8	M6	45	55	45	24	1	55	142
SQR8-R41	G1/4	M6	55	65	55	29	1	65	157

SQR10 十迴路 外觀尺寸圖 Dimensions

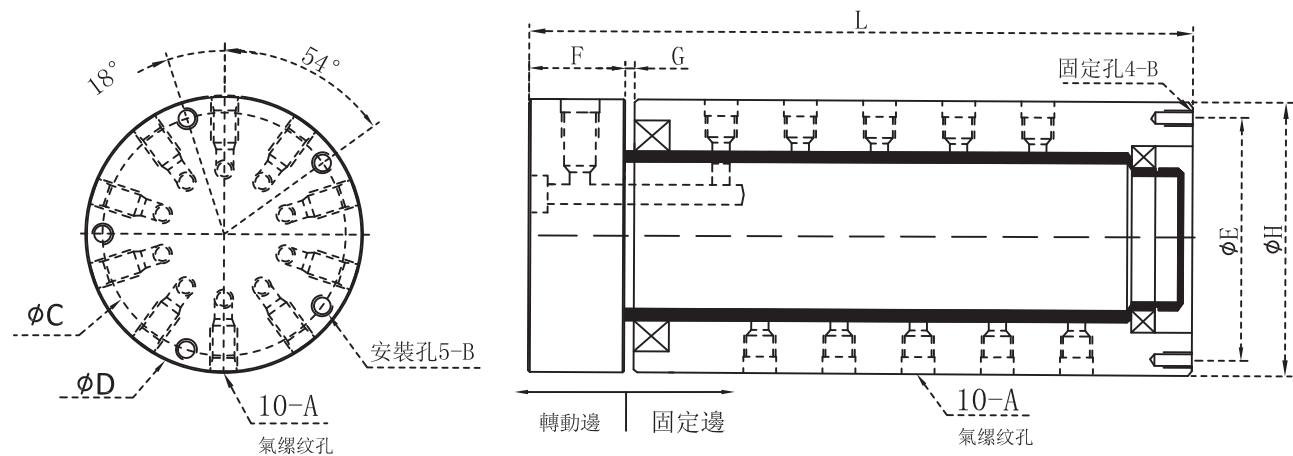

型號/尺寸	A	B	C	D	E	F	G	H	L
SQR10-R05	M5	M6	45	55	45	19	1	55	146
SQR10-R81	G1/8	M6	55	65	55	28	1	65	167
SQR10-R41	G1/4	M6	70	80	70	31	1	80	181

SQR

SQR12 十二迴路 外觀尺寸圖 Dimensions

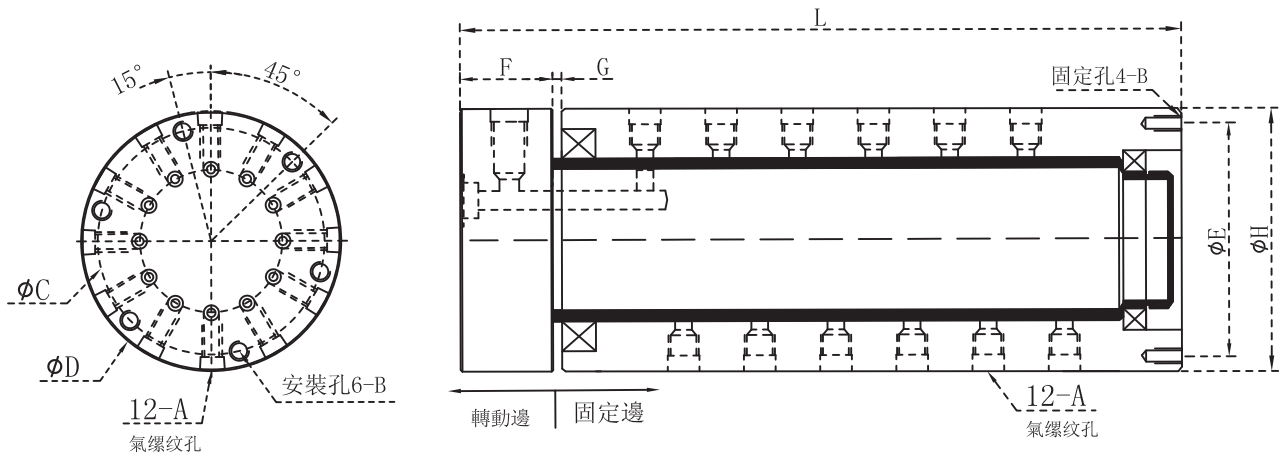

型號/尺寸	A	B	C	D	E	F	G	H	L
SQR12-R05	M5	M6	50	60	50	19	1	60	166
SQR12-R81	G1/8	M6	65	75	65	28	1	75	186
SQR12-R41	G1/4	M8	77	90	77	33	1	80	219

SQR16 十六迴路 外觀尺寸圖 Dimensions

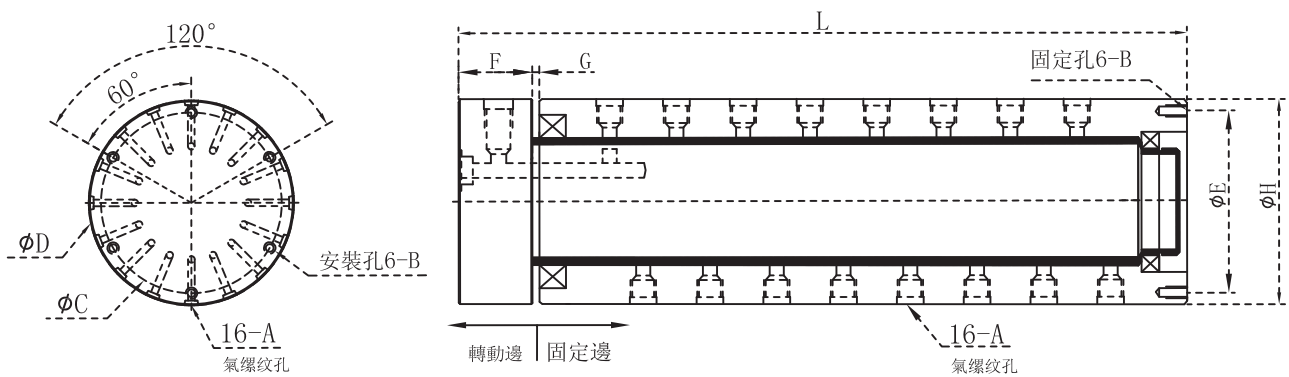

型號/尺寸	A	B	C	D	E	F	G	H	L
SQR16-R05	M5	M6	55	65	55	19	1	60	166
SQR16-R81	G1/8	M8	72	85	72	28	1	85	242
SQR16-R41	G1/4	M8	105	120	105	31	1	120	307