

技術資料 Technical data

型號 Model	SRH-P-30-E	
扭矩 Torque	Nm	10.6
旋轉角度 Rotation angle	N	180
調整角度 Adjust the angle	°	3.0
旋轉時間 Swiveling time with middle attached load	s	1.4
雙行程耗氣量 Double-stroke Air consumption	cm ³	196
可搭配機械夾爪 Can be used with mechanical jaws	兩爪: RGN+50; RGN+66; RGN+80; 三爪: RZN+50; RZN+66; RZN+80	
最大/最小壓力 Max. pressure	bar	5/8
最小/最大溫度 Min. /max. temperature	°C	5 - 80
夾爪關閉/開啟時間 Gripping Closing/opening Time	s	0.5
IP等級 IP Class	IP	65
重量 Weight	KG	4.8

PS:此模組不含夾爪本體及調速接頭 This module does not include clamping body and speed adjustment joint

訂購代號 How to code

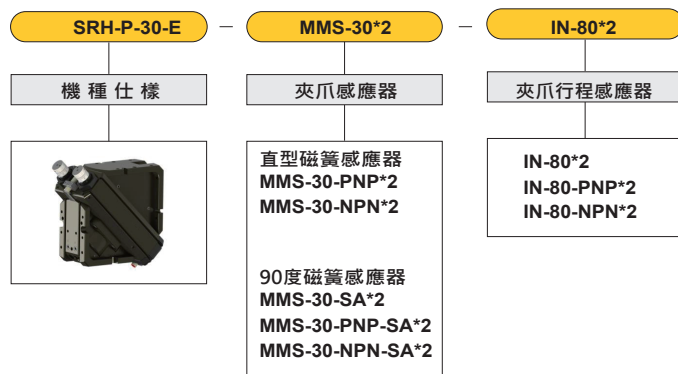

外觀尺寸圖 Dimensions

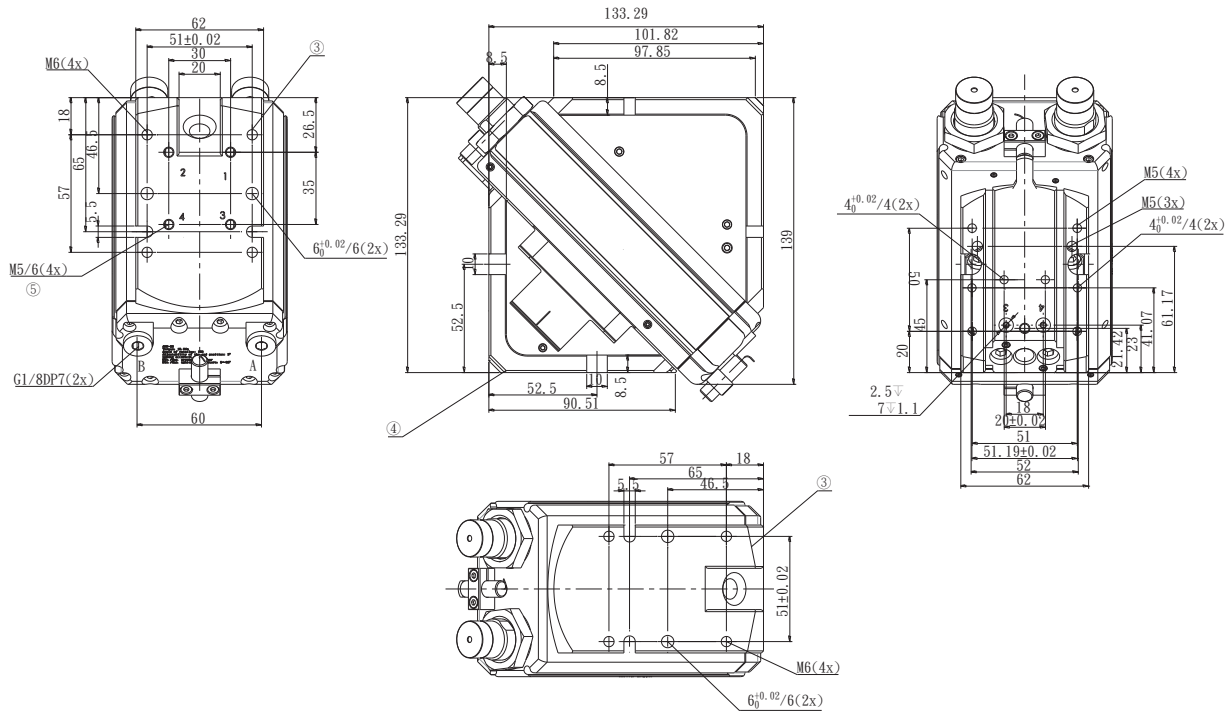

- A 轉位模組順時針旋轉進氣口； The indexing unit rotates the air inlet clockwise
 B 轉位模組逆時針旋轉進氣口； The indexing unit rotates the air intake counterclockwise;
- ③ 轉位模組連接板 Indexing module connection plate
 - ④ 夾爪模組連接板 Clamp module connection plate
 - ⑤ 轉位模組供氣孔 Indexing the supply hole of the module

SRH-P-30-E

● 旋轉模組與連接板示意圖

直接連接供氣接口，免管線，連接板與機械夾爪氣孔直接相接，壓縮空氣可直接供氣給機械夾爪使用

Direct connection to air supply, free piping, connecting plate and machine The jaws are directly connected to the stoma, and the compressed air can be supplied directly Gas is used for mechanical jaws

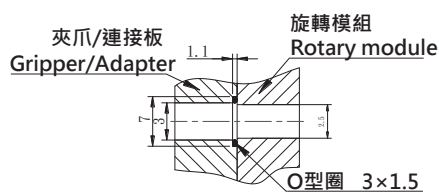

● 三角模塊與夾爪法蘭界面

Hose-free direct connection

直接連接供氣接口，免管路，轉接板與夾爪供氣孔直接相通，壓縮空氣直接供機械夾爪使用。Direct link air supply port, compressed air supplied directly to the grippers without hoses, the pressure medium can be fed through bore-holes in the mounting plate.

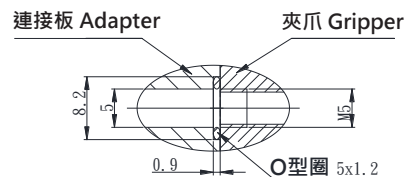

- (無接觸式)近接感應器開關
(Contactless) proximity sensor switch

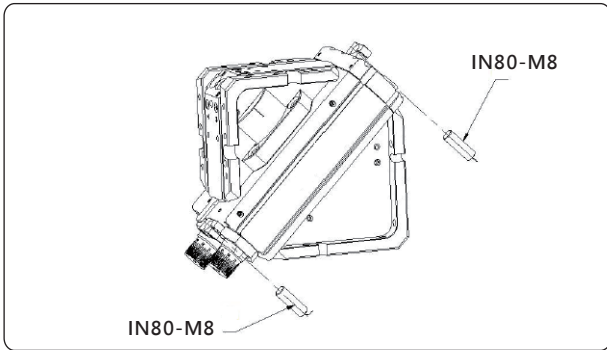

- (無接觸式)側邊終端位置監控:
旋轉缸模組感應器, 可直接由側邊安裝。
- 每個旋轉缸模組需要至少2個感應器(無接觸式)。
- (Non-contact) side terminal position monitoring:
Rotary cylinder module sensor, can be installed directly from the side
- Each rotary cylinder module requires at least two sensors (no contact).

型號 Model	建議使用數量 Recom. number of use
IN80-M8	2
IN80-M8-NPN	2
IN80-M8-PNP	2

- (接觸式)磁簧式C型槽感應器開關
(Contact type) reed type C-slot sensor switch

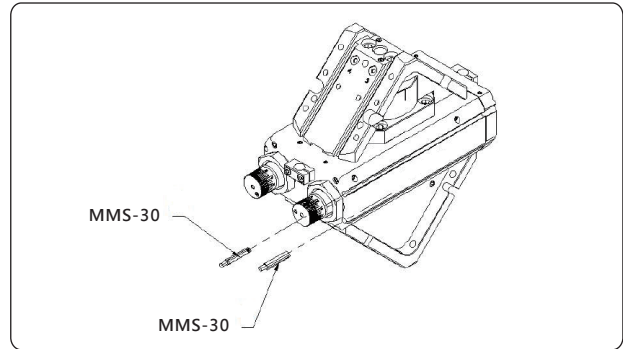

- 接觸式C型槽終端位置監控:
旋轉缸模組感應器, 安裝於夾爪C型槽內。
- 每個旋轉缸模組需要至少2個感應器(接觸式)。
- Contact C-slot terminal position monitoring:
Rotary cylinder module sensor, installed in the jaw C-slot.
- Each rotary cylinder module requires at least two sensors (contact type).

型號 Model	型式 Description	建議使用數量 Recom. number of use
MMS-30	直行設計(兩線無接點) Straight design (two-line non-contact)	2
MMS-30-PNP	直行設計(三線接點) Straight design (two-line non-contact)	2
MMS-30-NPN	直行設計(三線接點) Straight design (two-line non-contact)	2
MMS-30-SA	90度設計(兩線無接點) 90 degrees design (two-line non-contact)	2
MMS-30-PNP-SA	90度設計(三線接點) 90 degrees design (two-line non-contact)	2
MMS-30-NPN-SA	90度設計(三線接點) 90 degrees design (two-line non-contact)	2

- 夾爪調速閥 Speed control valve

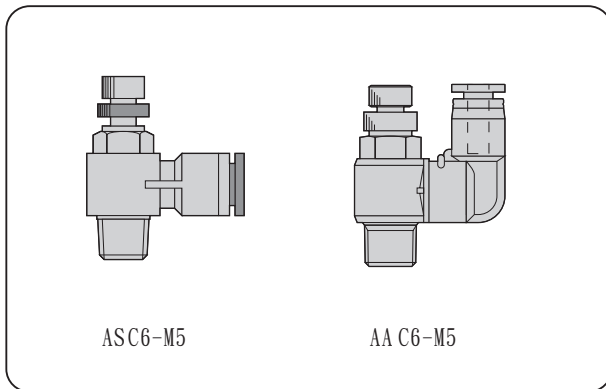

- 機械夾爪專用調速閥:
調整夾爪開張速度專用調速閥門
- 每個旋轉模組需要至少4個調速閥。
- Mechanical jaw special speed control valve:
Adjust the jaw opening speed special speed control valve
- Each rotary module requires at least four speed control valves.

型號 Model	型式 Description	建議使用數量 Recom. number of use
ASC6-M5	90度設計 Ø6管徑 90 degrees design ø6 diameter	2
AAC6-M5	直通設計 Ø6管徑 Straight design ø6 diameter	2

- 旋轉模組中心出線孔
Rotate the module center outlet hole

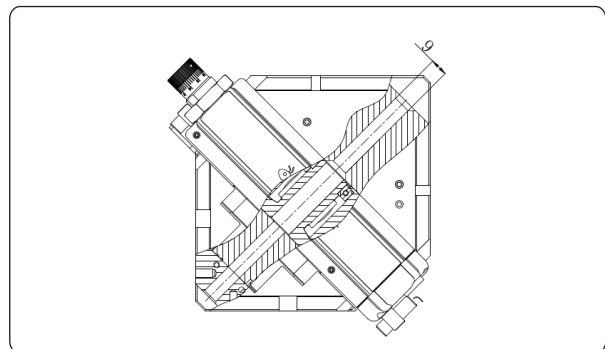

- 設置內部走線孔, 和避免線因旋轉等原因造成破壞
- Set the internal alignment hole, and avoid the line due to rotation and other reasons made into ruin

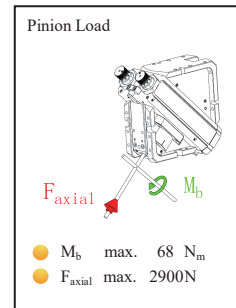

技術資料 Technical data

型號 Model	SRH-P-40-E	
扭矩 Torque	Nm	22.6
旋轉角度 Rotation angle	N	180
調整角度 Adjust the angle	°	3.0
旋轉時間 Swiveling time with middle attached load	s	1.8
雙行程耗氣量 Double-stroke Air consumption	cm ³	322
可搭配機械夾爪 Can be used with mechanical jaws	兩爪: RGN+80 ; RGN+100 ; 三爪: RZN+80 ; RZN+100	
最大/最小壓力 Max. pressure	bar	5/8
最小/最大溫度 Min. /max. temperature	°C	5 - 80
夾爪關閉/開啟時間 Gripping Closing/opening Time	s	0.5
IP等級 IP Class	IP	65
重量 Weight	KG	6.87

訂購代號 How to code

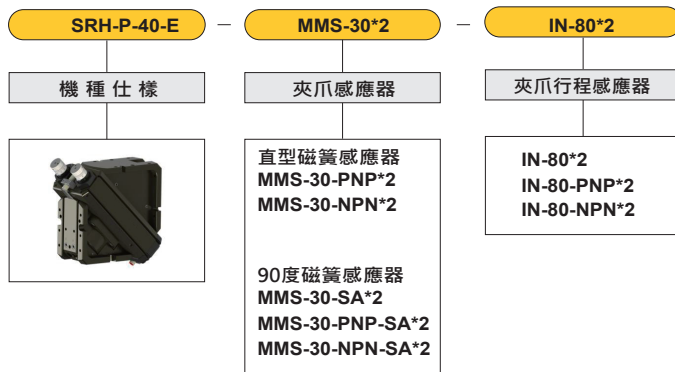

SRH-P-40-E 外觀尺寸圖 Dimensions

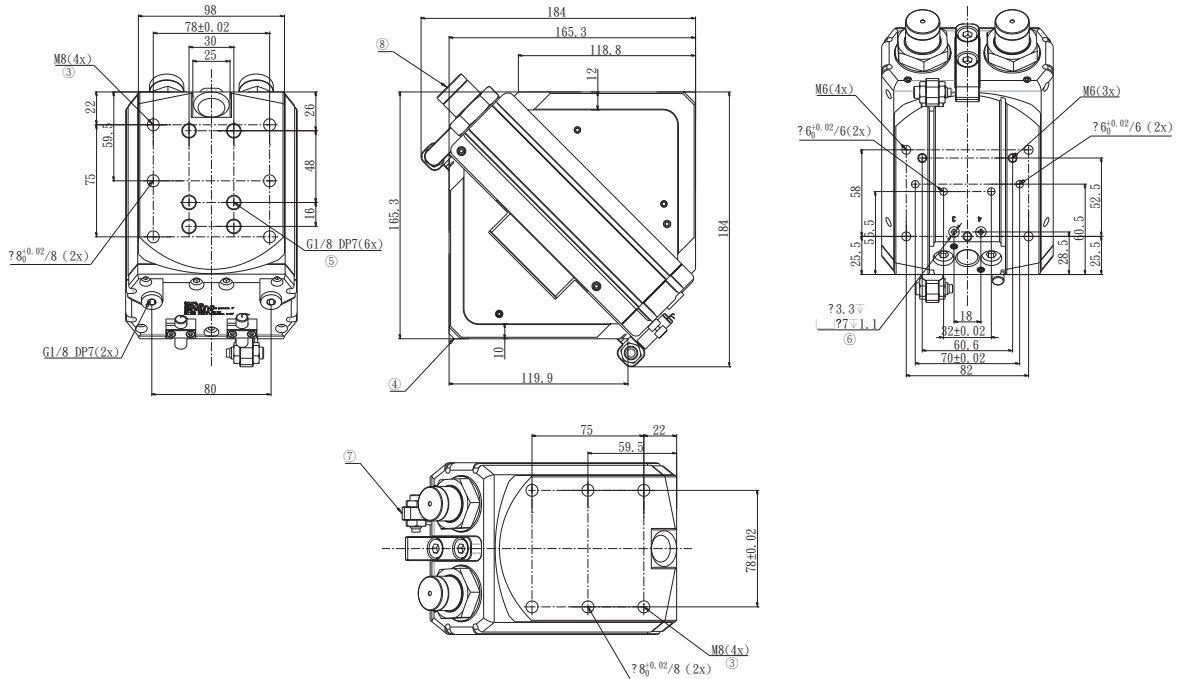

- A 轉位模組順時針旋轉進氣口； The indexing unit rotates the air inlet clockwise
- B 轉位模組逆時針旋轉進氣口； The indexing unit rotates the air intake counterclockwise;
- ③ 轉位模組連接板 Indexing module connection plate
- ④ 夾爪模組連接板 Clamp module connection plate
- ⑤ 轉位模組供氣孔 Indexing the supply hole of the module

● 旋轉模組與連接板示意圖 Schematic diagram of rotating module and connecting plate

直接連接供氣接口，免管線，連接板與機械夾爪氣孔直接相接，壓縮空氣可直接供氣給機械夾爪使用
Direct connection to air supply, free piping, connecting plate and machine The jaws are directly connected to the stoma, and the compressed air can be supplied directly Gas is used for mechanical jaws

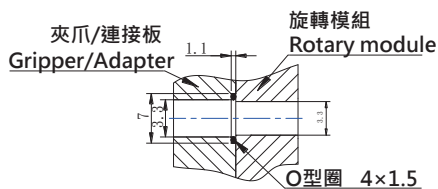

● 三角模塊與夾爪法蘭界面 Hose-free direct connection

直接連接供氣接口，免管路，轉接板與夾爪供氣孔直接相通，壓縮空氣直接供機械夾爪使用。
Direct link air supply port, compressed air supplied directly to the grippers without hoses, the pressure medium can be fed through bore-holes in the mounting plate.

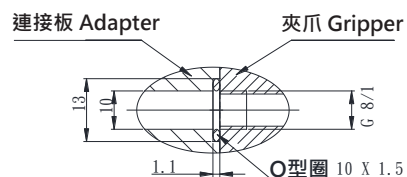

SRH-P-40-E

- (無接觸式)近接感應器開關
(Contactless) proximity sensor switch

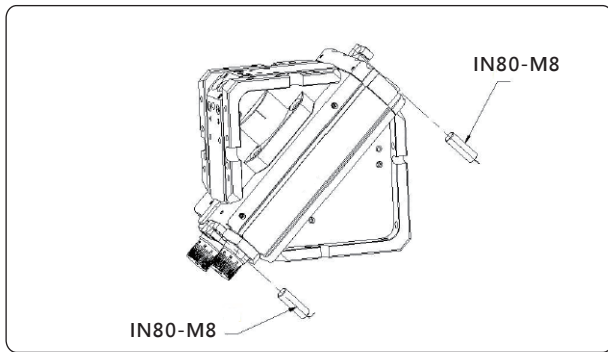

- (無接觸式)側邊終端位置監控:
旋轉缸模組感應器，可直接由側邊安裝。
- 每個旋轉缸模組需要至少2個感應器(無接觸式)。
- (Non-contact) side terminal position monitoring:
Rotary cylinder module sensor, can be installed directly from the side
- Each rotary cylinder module requires at least two sensors (no contact).

型號 Model	建議使用數量 Recom. number of use
IN80-M8	2
IN80-M8-NPN	2
IN80-M8-PNP	2

- 夾爪調速閥 Speed control valve

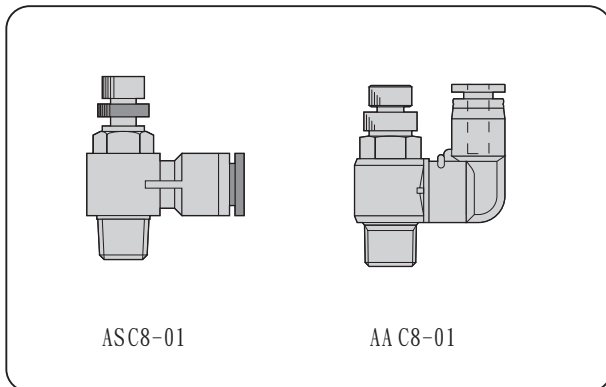

- 機械夾爪專用調速閥:
調整夾爪開張速度專用調速閥門
- 每個旋轉模組需要至少4個調速閥。
- Mechanical jaw special speed control valve:
Adjust the jaw opening speed special speed control valve
- Each rotary module requires at least four speed control valves.

型號 Model	型式 Description	建議使用數量 Recom. number of use
ASC8-01	90度設計 Ø8管徑 90 degrees design ø6 diameter	2
AAC8-01	直通設計 Ø8管徑 Straight design ø6 diameter	2

- (接觸式)磁簧式C型槽感應器開關
(Contact type) reed type C-slot sensor switch

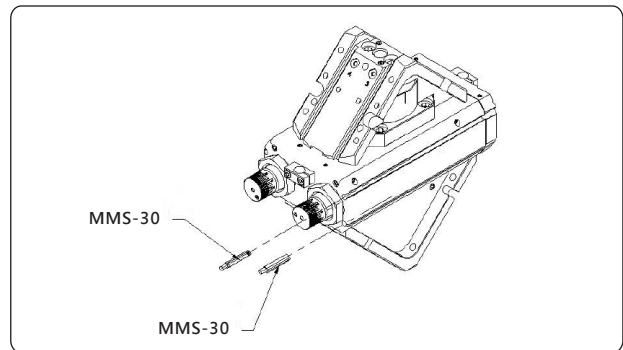

- 接觸式C型槽終端位置監控:
旋轉缸模組感應器，安裝於夾爪C型槽內。
- 每個旋轉缸模組需要至少2個感應器(接觸式)。
- Contact C-slot terminal position monitoring:
Rotary cylinder module sensor, installed in the jaw C-slot.
- Each rotary cylinder module requires at least two sensors (contact type).

型號 Model	型式 Description	建議使用數量 Recom. number of use
MMS-30	直行設計(兩線無接點) Straight design (two-line non-contact)	2
MMS-30-PNP	直行設計(三線接點) Straight design (two-line non-contact)	2
MMS-30-NPN	直行設計(三線接點) Straight design (two-line non-contact)	2
MMS-30-SA	90度設計(兩線無接點) 90 degrees design (two-line non-contact)	2
MMS-30-PNP-SA	90度設計(三線接點) 90 degrees design (two-line non-contact)	2
MMS-30-NPN-SA	90度設計(三線接點) 90 degrees design (two-line non-contact)	2

- 旋轉模組中心出線孔
Rotate the module center outlet hole

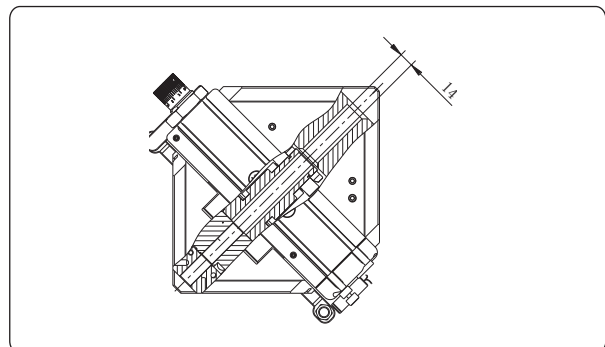

- 設置內部走線孔，和避免線因旋轉等原因造成破壞
- Set the internal alignment hole, and avoid the line due to rotation and other reasons made into ruin

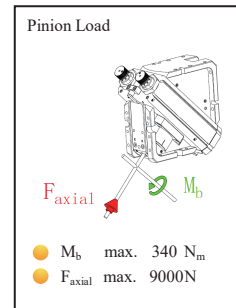

技術資料 Technical data

型號 Model	SRH-P-50-E	
扭矩 Torque	Nm	49.5
旋轉角度 Rotation angle	N	180
調整角度 Adjust the angle	°	3.0
旋轉時間 Swiveling time with middle attached load	s	2.2
雙行程耗氣量 Double-stroke Air consumption	cm ³	560
可搭配機械夾爪 Can be used with mechanical jaws	兩爪: RGN+100 ; RGN+125 ; 三爪: RZN+100 ; RZN+125	
最大/最小壓力 Max. pressure	bar	5/8
最小/最大溫度 Min. /max. temperature	°C	5 - 80
夾爪關閉/開啟時間 Gripping Closing/opening Time	s	0.5
IP等級 IP Class	IP	65
重量 Weight	KG	7.95

訂購代號 How to code

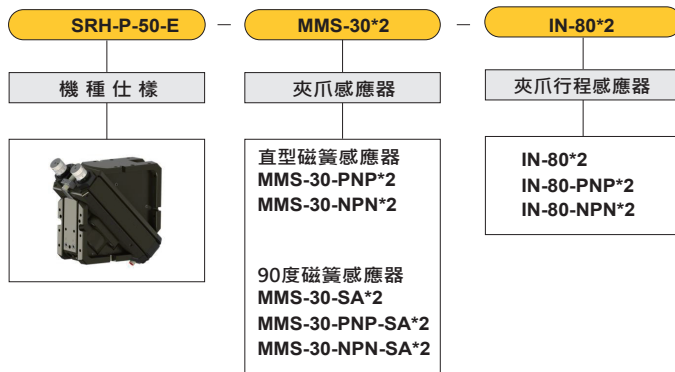

SRH-P-50-E 外觀尺寸圖 Dimensions

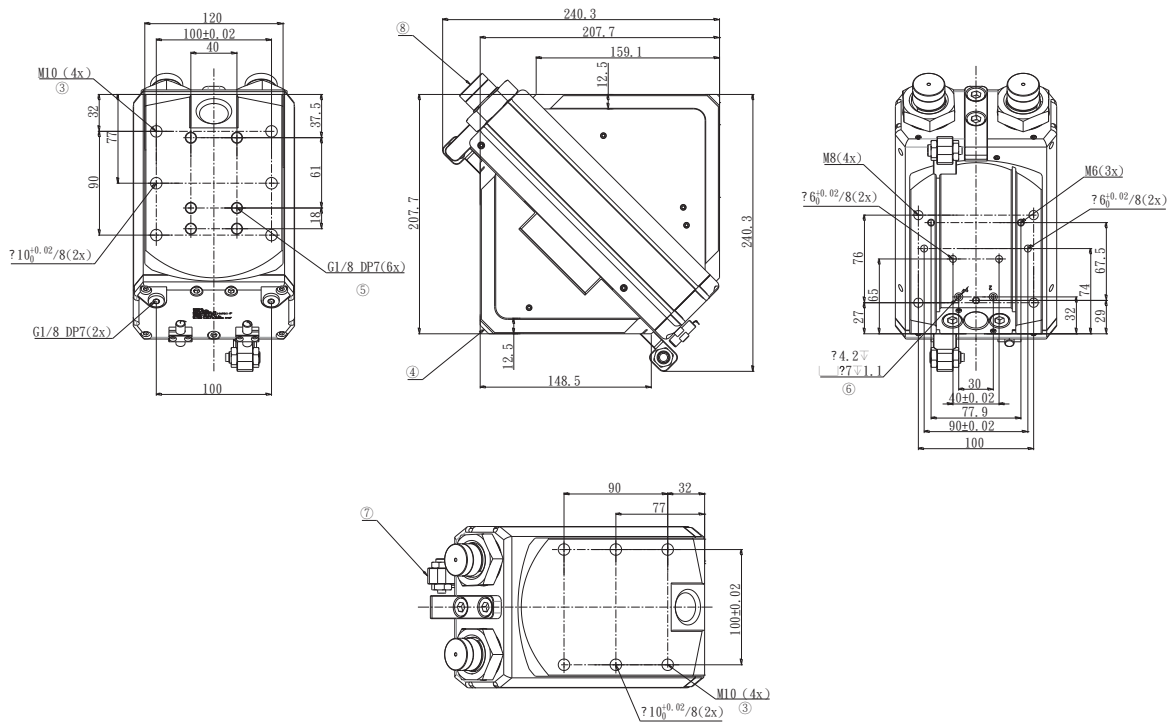

- A 轉位模組順時針旋轉進氣口； The indexing unit rotates the air inlet clockwise
 B 轉位模組逆時針旋轉進氣口； The indexing unit rotates the air intake counterclockwise;
 ③ 轉位模組連接板 Indexing module connection plate
 ④ 夾爪模組連接板 Clamp module connection plate
 ⑤ 轉位模組供氣孔 Indexing the supply hole of the module

● 旋轉模組與連接板示意圖

直接連接供氣接口，免管線，連接板與機械夾爪氣孔直接相接，壓縮空氣可直接供氣給機械夾爪使用

Direct connection to air supply, free piping, connecting plate and machine The jaws are directly connected to the stoma, and the compressed air can be supplied directly Gas is used for mechanical jaws

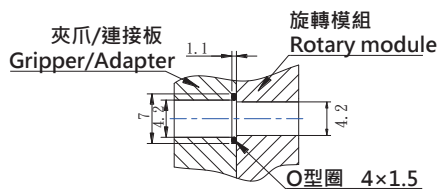

● 三角模塊與夾爪法蘭界面 Hose-free direct connection

直接連接供氣接口，免管路，轉接板與夾爪供氣孔直接相通，壓縮空氣直接供機械夾爪使用。 Direct link air supply port, compressed air supplied directly to the grippers without hoses, the pressure medium can be fed through bore-holes in the mounting plate.

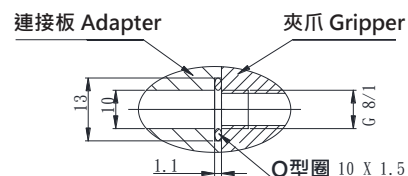

- (無接觸式)近接感應器開關
(Contactless) proximity sensor switch

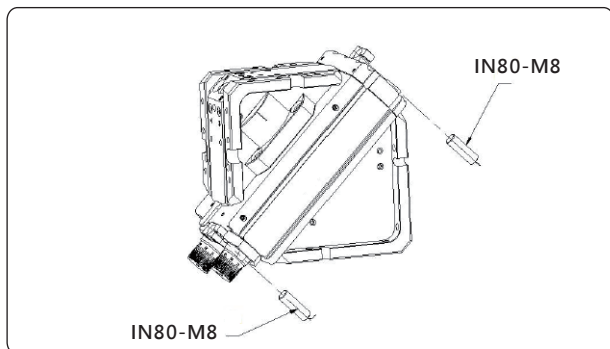

- (無接觸式)側邊終端位置監控:
旋轉缸模組感應器，可直接由側邊安裝。
- 每個旋轉缸模組需要至少2個感應器(無接觸式)。
- (Non-contact) side terminal position monitoring:
Rotary cylinder module sensor, can be installed directly from the side
- Each rotary cylinder module requires at least two sensors (no contact).

型號 Model	建議使用數量 Recom. number of use
IN80-M8	2
IN80-M8-NPN	2
IN80-M8-PNP	2

- 夾爪調速閥 Speed control valve

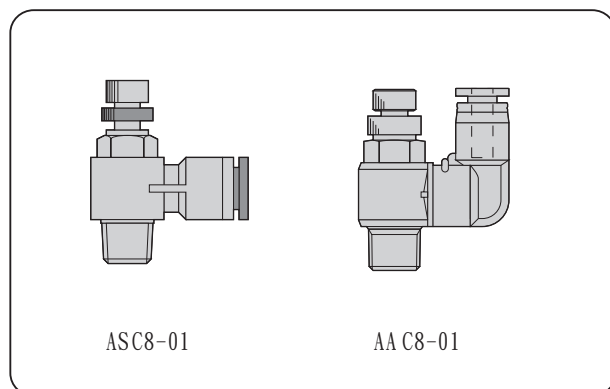

- 機械夾爪專用調速閥:
調整夾爪開張速度專用調速閥門
- 每個旋轉模組需要至少4個調速閥。
- Mechanical jaw special speed control valve:
Adjust the jaw opening speed special speed control valve
- Each rotary module requires at least four speed control valves.

型號 Model	型式 Description	建議使用數量 Recom. number of use
ASC8-01	90度設計 Ø8管徑 90 degrees design ø6 diameter	2
AAC8-01	直通設計 Ø8管徑 Straight design ø6 diameter	2

- (接觸式)磁簧式C型槽感應器開關
(Contact type) reed type C-slot sensor switch

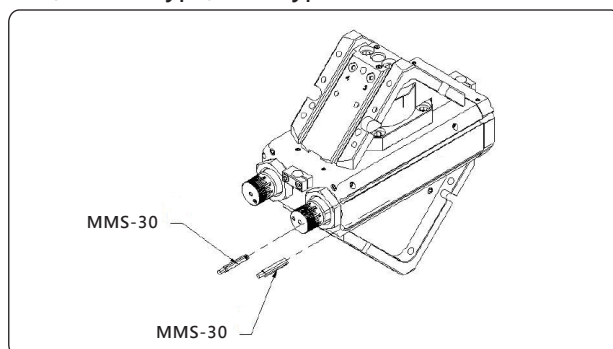

- 接觸式C型槽終端位置監控:
旋轉缸模組感應器，安裝於夾爪C型槽內。
- 每個旋轉缸模組需要至少2個感應器(接觸式)。
- Contact C-slot terminal position monitoring:
Rotary cylinder module sensor, installed in the jaw C-slot.
- Each rotary cylinder module requires at least two sensors (contact type).

型號 Model	型式 Description	建議使用數量 Recom. number of use
MMS-30	直行設計(兩線無接點) Straight design (two-line non-contact)	2
MMS-30-PNP	直行設計(三線接點) Straight design (two-line non-contact)	2
MMS-30-NPN	直行設計(三線接點) Straight design (two-line non-contact)	2
MMS-30-SA	90度設計(兩線無接點) 90 degrees design (two-line non-contact)	2
MMS-30-PNP-SA	90度設計(三線接點) 90 degrees design (two-line non-contact)	2
MMS-30-NPN-SA	90度設計(三線接點) 90 degrees design (two-line non-contact)	2

- 旋轉模組中心出線孔
Rotate the module center outlet hole

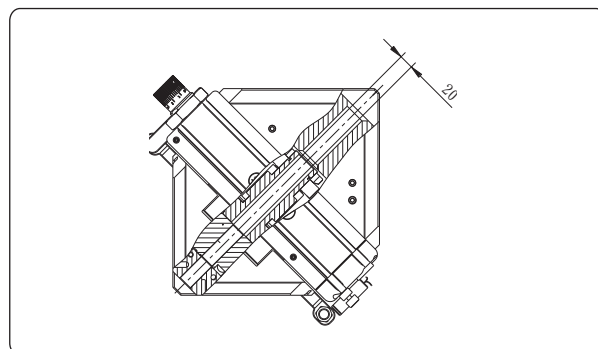

- 設置內部走線孔，和避免線因旋轉等原因造成破壞
- Set the internal alignment hole, and avoid the line due to rotation and other reasons made into ruin