

內部結構圖 Internal structure

### 規格表 Specification

機種 Model	SRU-10	SRU-20	SRU-30	SRU-50	SRU-70	SRU-100	SRU-200	SRU-300	SRU-500	
作動形式 Type of Operation	複動型 Double acting									
使用流體 Fluid	空氣 Air									
扭力 Torque	N·m	1.5	2.2	3.2	5.5	7.5	9.8	19	31	45
氣缸缸徑 Bore Size	Ø15	Ø18	Ø20	Ø25	Ø28	Ø32	Ø40	Ø50	Ø63	
搖動角度 Rotation Angle	180									
調整角度 Adjustable Angle	0° ~ 190°									
接管口徑 Port Size	M5 x 0.8P				Rc (PT 1/8")					
使用壓力 Pressure Range	kgf/cm2 (kpa)	1.5 ~ 7 (150 ~ 700)								
使用溫度範圍 Range of Service Temperature	°C	0 ~ 50								
油壓緩衝器 Shock Absorber		0.039	0.116	0.116	0.294	1.1	1.6	2.9	3.5	5.2
重量 Weight	kg	0.53	0.99	1.25	2.1	2.89	4.1	7.65	8.96	11.17

### 訂購稱呼代號 How to eoder

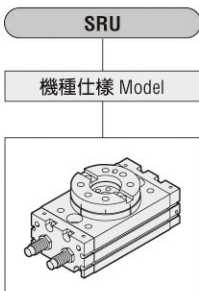

SRU 系列  
迴轉氣缸 Rotary cylinder

**10**

扭力 Torque

10 : 1.5 N·m
20 : 2.2 N·m
30 : 3.2 N·m
50 : 5.5 N·m
70 : 7.5 N·m
100 : 9.8 N·m
200 : 19.0 N·m
300 : 31.0 N·m
500 : 49.0 N·m

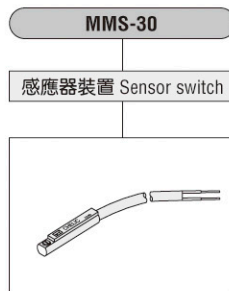

無記號 : 不附感應器  
None: without sensor switch

型號 Model	型式 Description	建議使用數量 Recom. number of use
MMS-30	直行設計 (兩線無接點) Straight design (two-line non-contact)	2
MMS-30-SA	90度設計 (兩線無接點) 90 degrees design (two-line non-contact)	2

## 使用條件說明 Exercise teams explanation

### ▶ 迴轉方向與迴轉角度 Rotary direction and Rotation angle

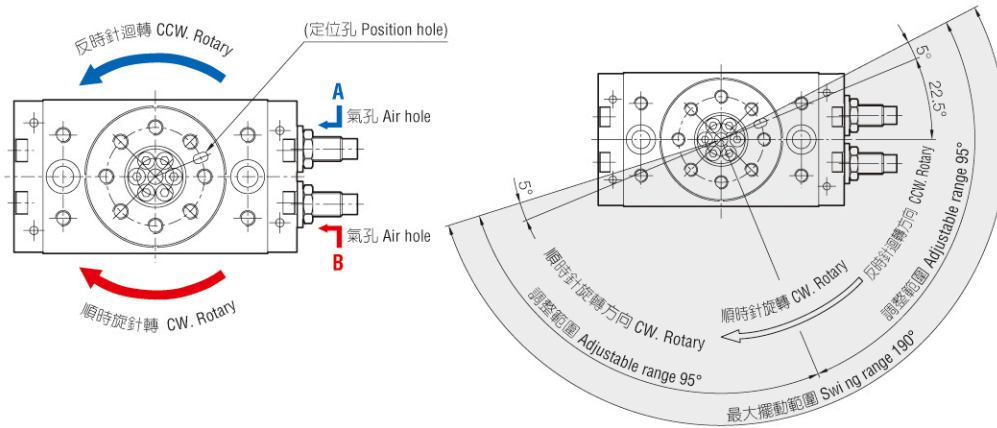

### ▶ 迴轉角度範圍之設定 Set of Rotation range

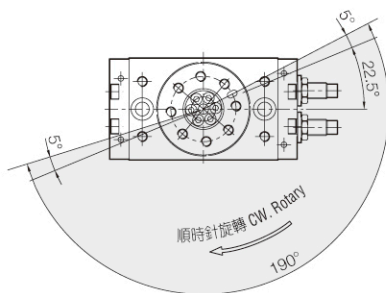

● 190° 迴轉 Swing rotation

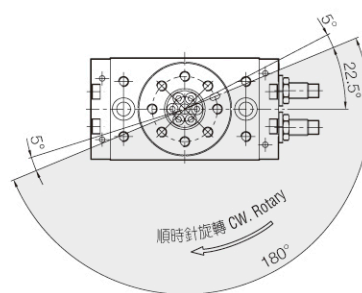

● 180° 迴轉 Swing rotation

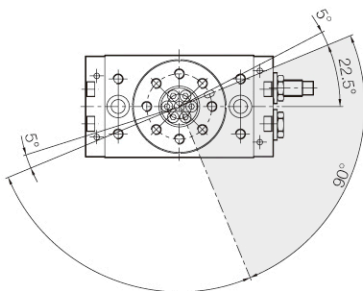

● 90° 迴轉 Swing rotation

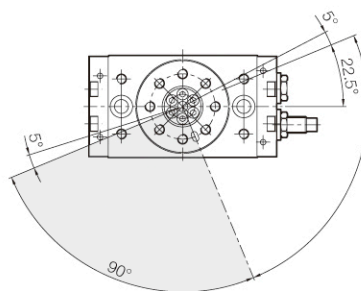

● 90° 迴轉 Swing rotation

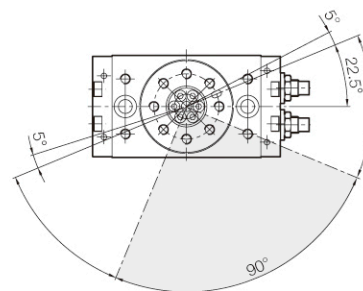

● 90° 迴轉 Swing rotation

### 使用條件說明 Exercise teams explanation

#### 容許負載和變形量 Transverse load and Deflection

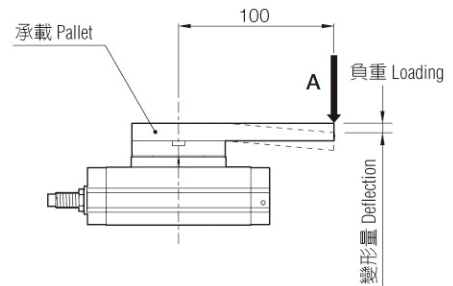
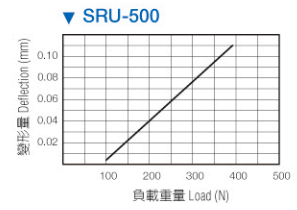
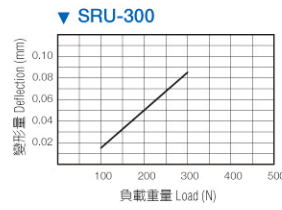
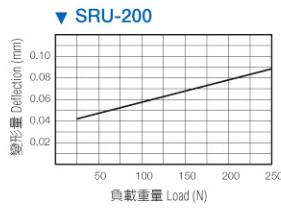
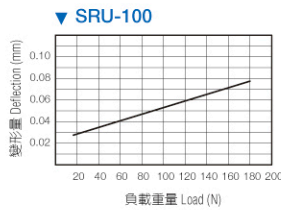
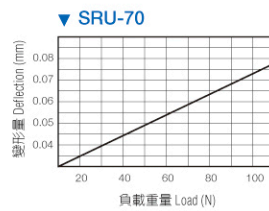
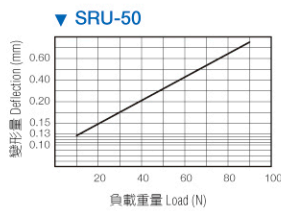
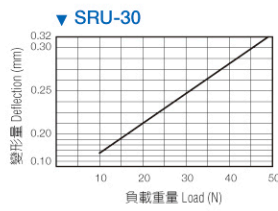
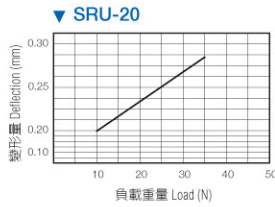
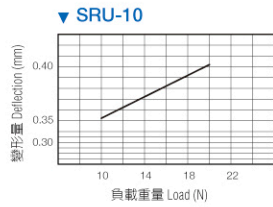

#### 允許負重 Allow load

負載方向 Loading way	缸徑 Type	轉盤負載 Table load (N)		允許扭力 Allow torque (N.m)	
		(a)	(b)		
	側邊負載 Side load(N)				
	SRU-10	70	78	74	2
	SRU-20	140	130	130	3.5
	SRU-30	185	188	358	4.8
	SRU-50	300	285	442	9
	SRU-70	333	296	476	12
	SRU-100	390	493	706	18
	SRU-200	543	740	1009	25
	SRU-300	850	950	1500	30
SRU-500	1200	1400	2100	38	

## 外觀尺寸 External dimension

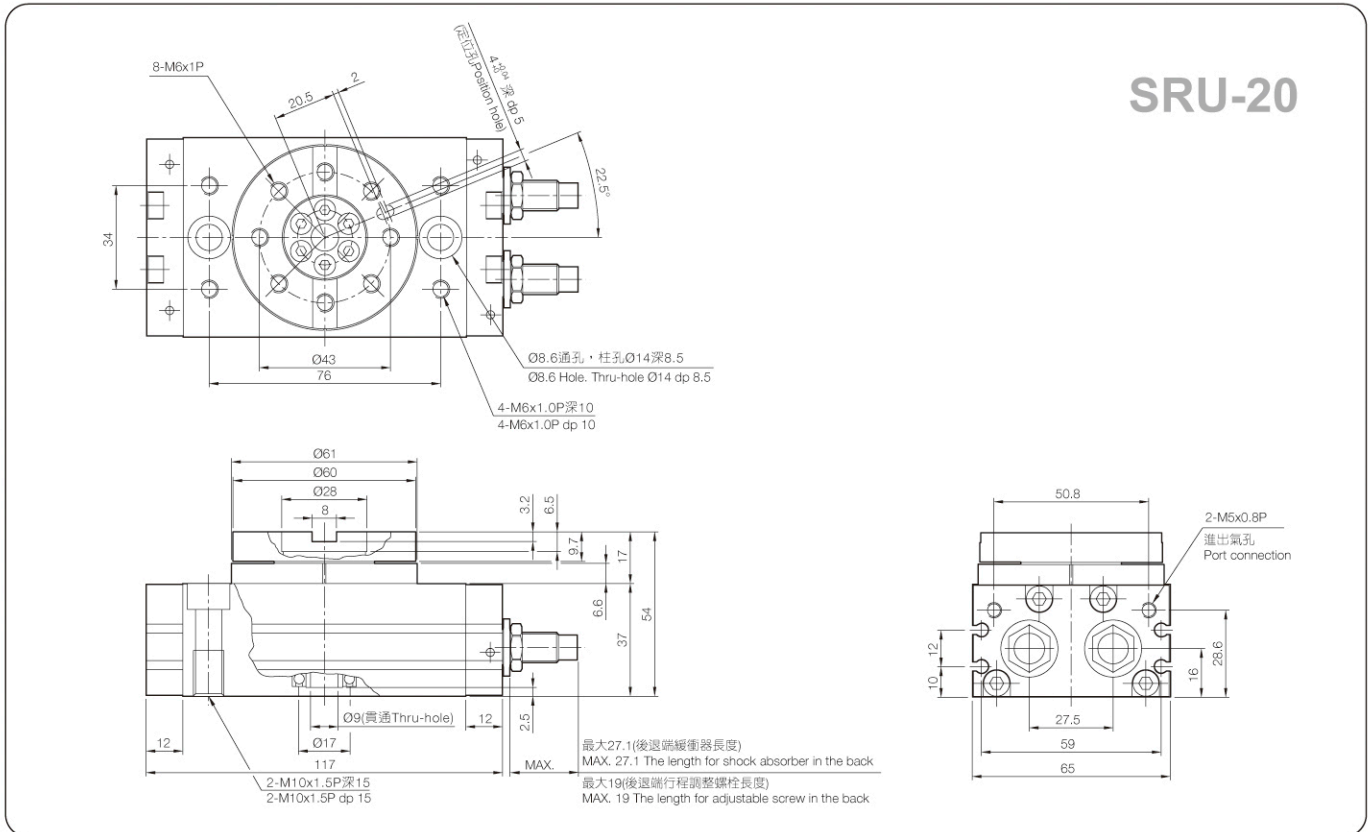
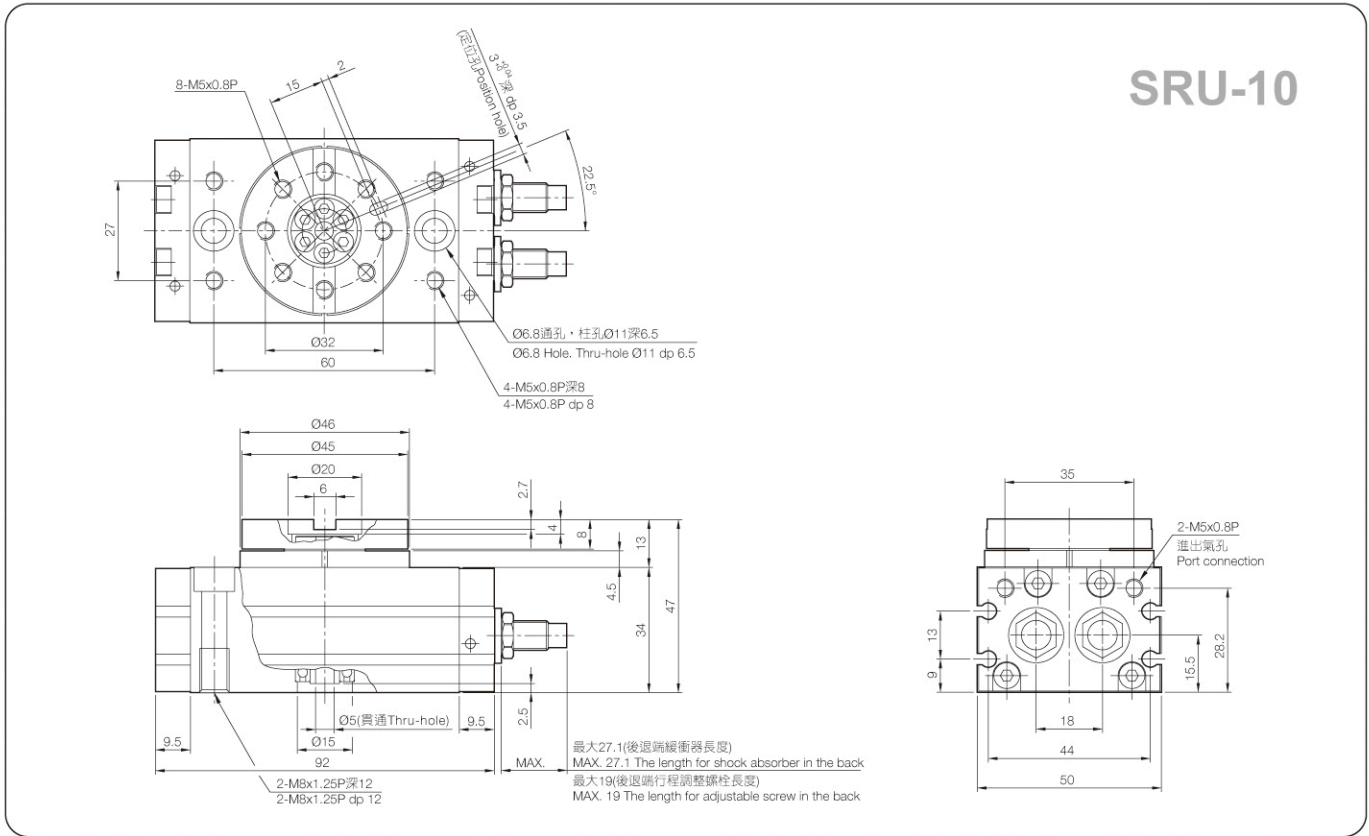

SRU TYPE

外觀尺寸 External dimension

SRU-30

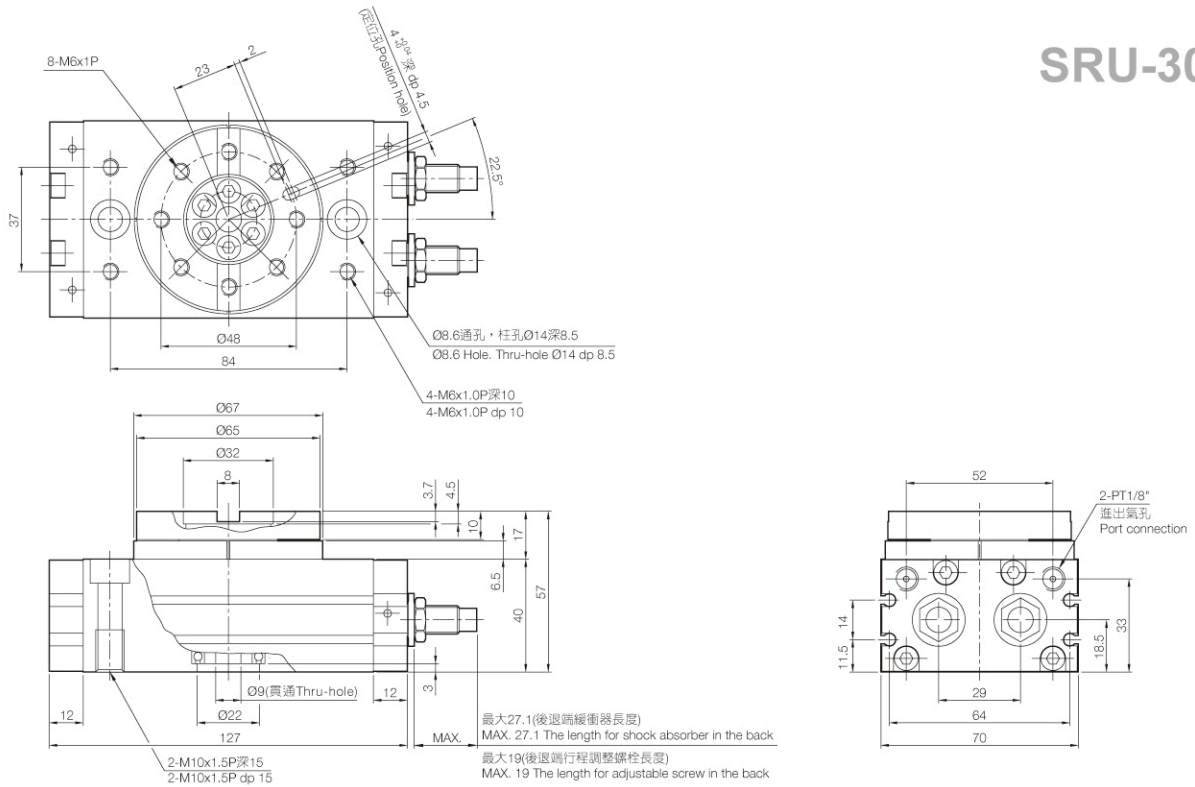

SRU-50

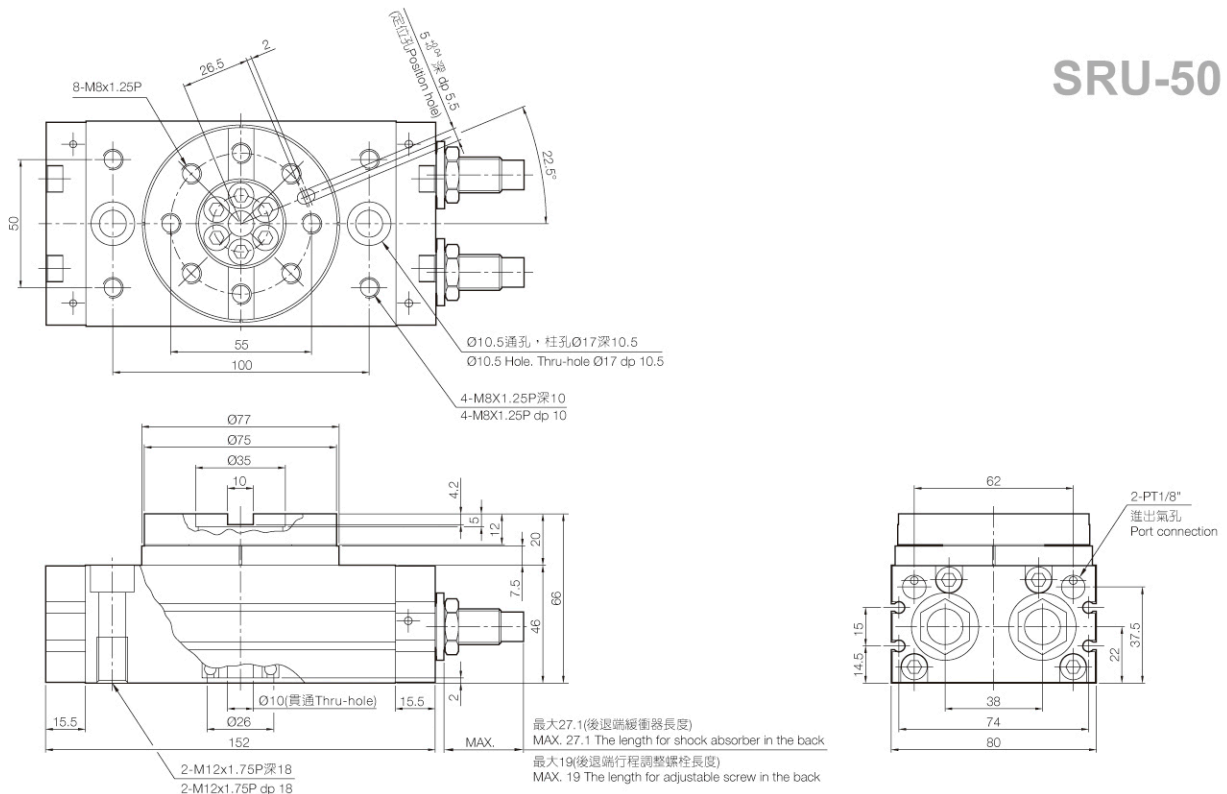

## 外觀尺寸 External dimension

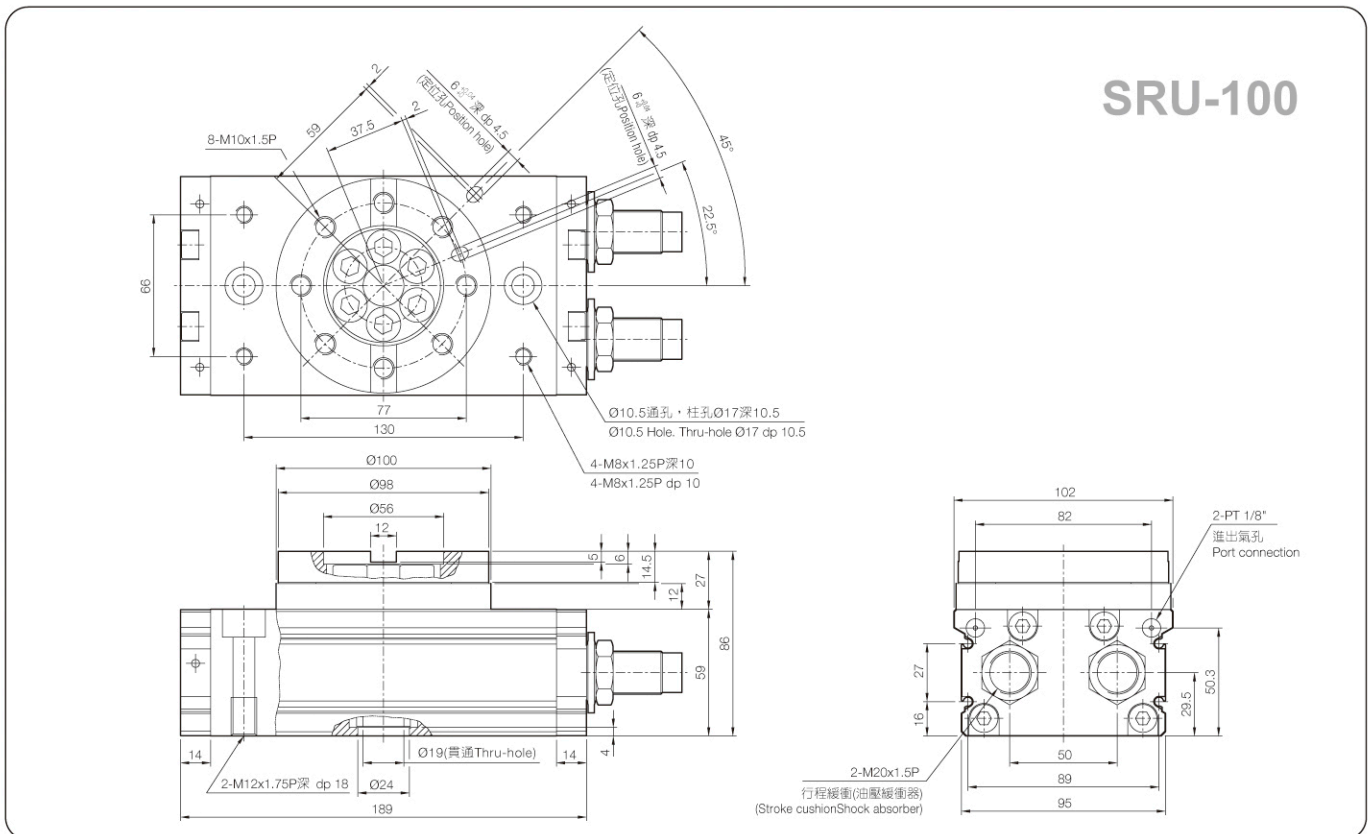
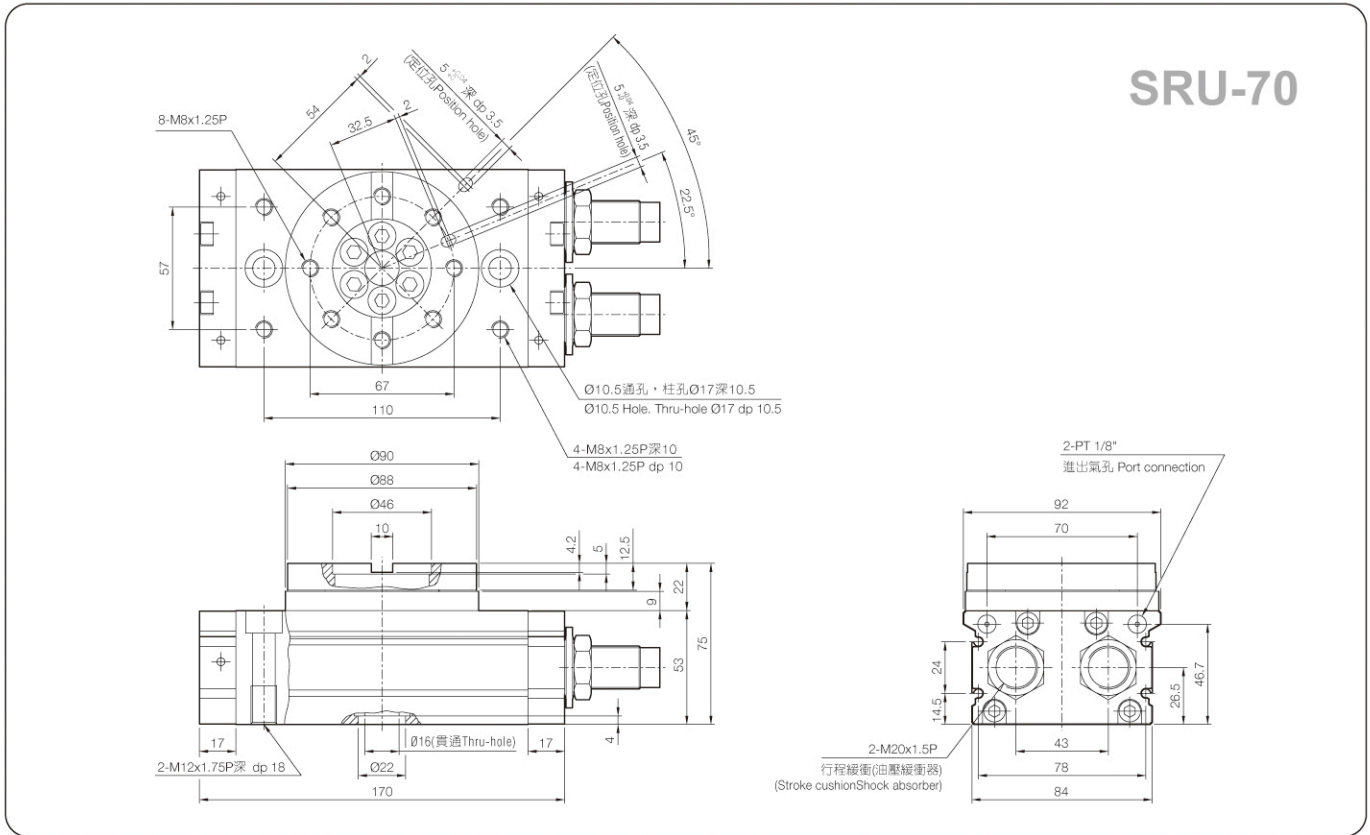

SRU TYPE

外觀尺寸 External dimension

SRU-200

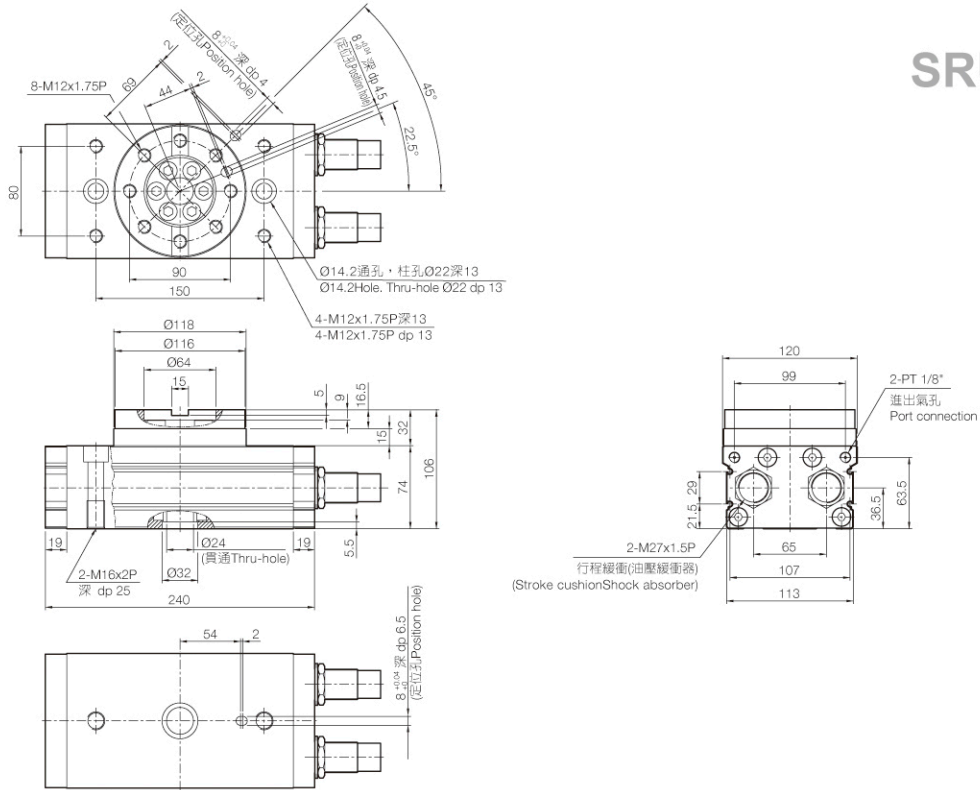

SRU-300

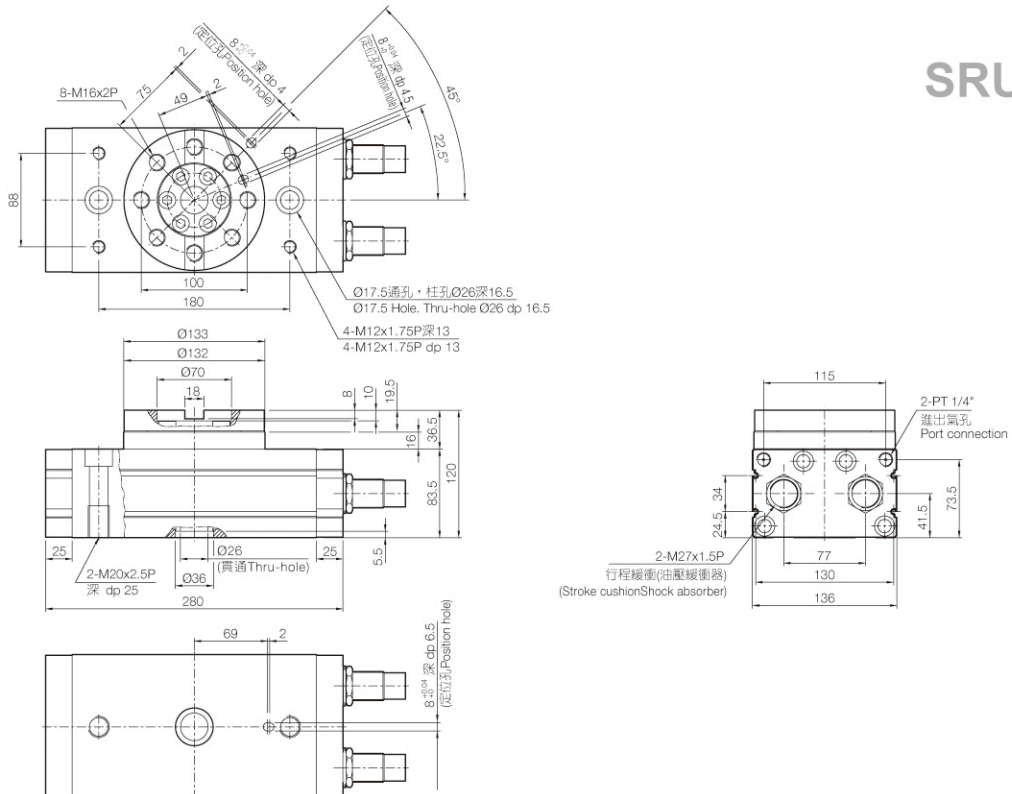

外觀尺寸 External dimension

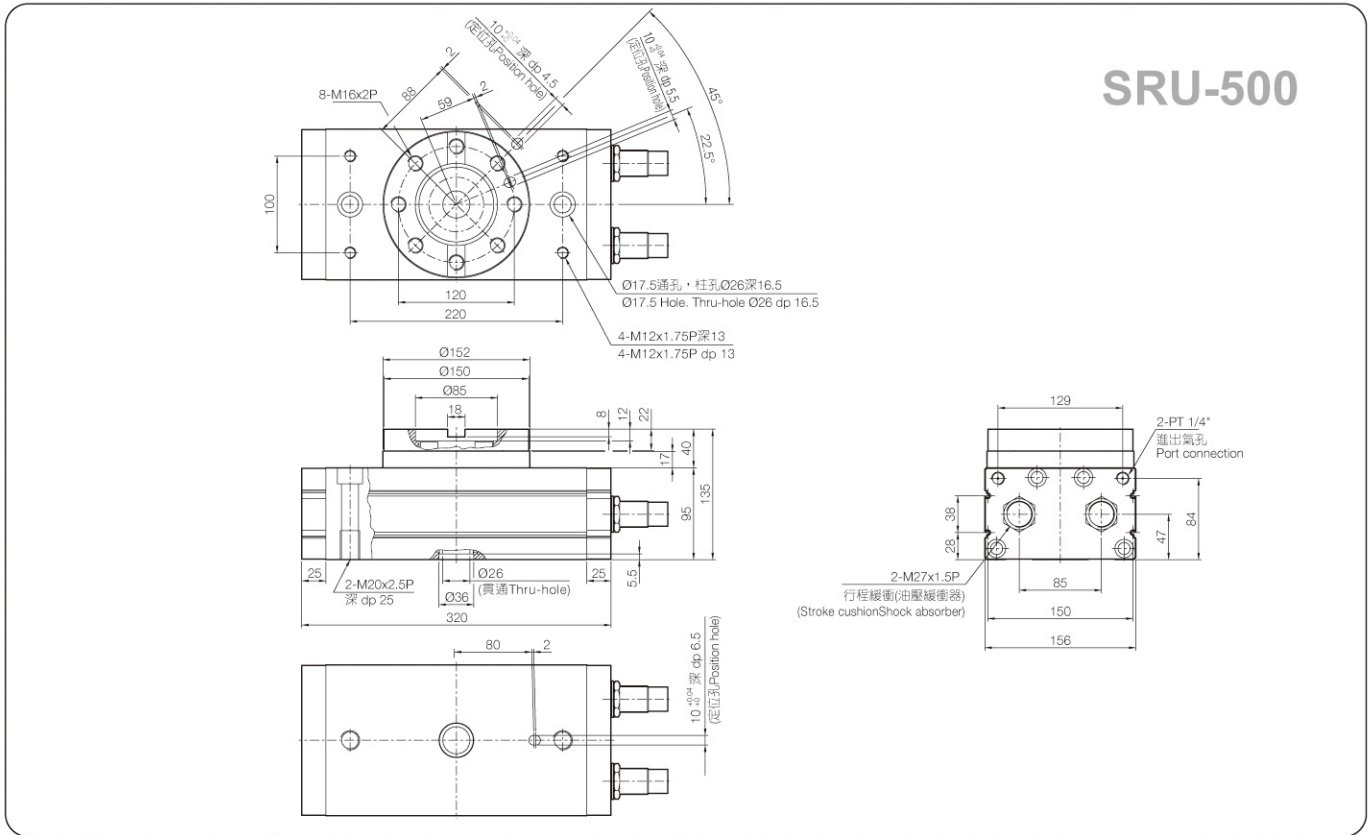

SRU TYPE